

Product Specification Sheet

Product name – Cranked Wheel Guides Pair

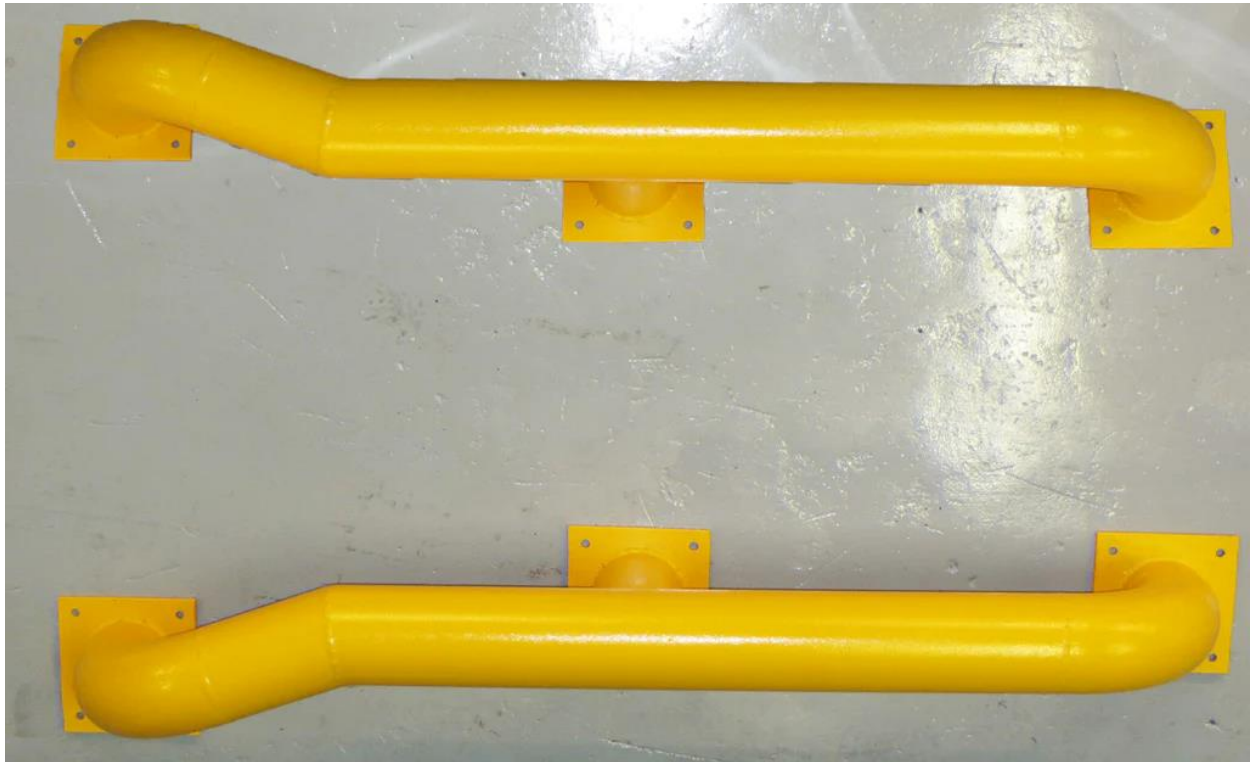

Manufacturer / Brand	Polymer
Warranty	1 year manufacturer's warranty
Material	Hot-dip galvanised steel
Components	2 x single piece guide with base plate
Dimensions	2040(L) x 405(W) x 365(H)mm
Weight	116kg (per pair)
Features	2070(L) x 600(W) x 365(H)mm High quality steel design - highly durable Splayed ends to act as drivers aid Ideal for loading bays and freight depots Easy installation - 12 fixing points per unit Drivers can line up trailers correctly

Ireland:
B2 Athy Business Campus
Athy, Co. Kildare R14 PK74
Ph: 01 531 2777
Email: sales@pittman.ie

United Kingdom:
1310 Solihull Parkway, Birmingham Business Park
Birmingham B37 7YB
Ph: 0121 630 3527
sales@pittman.uk

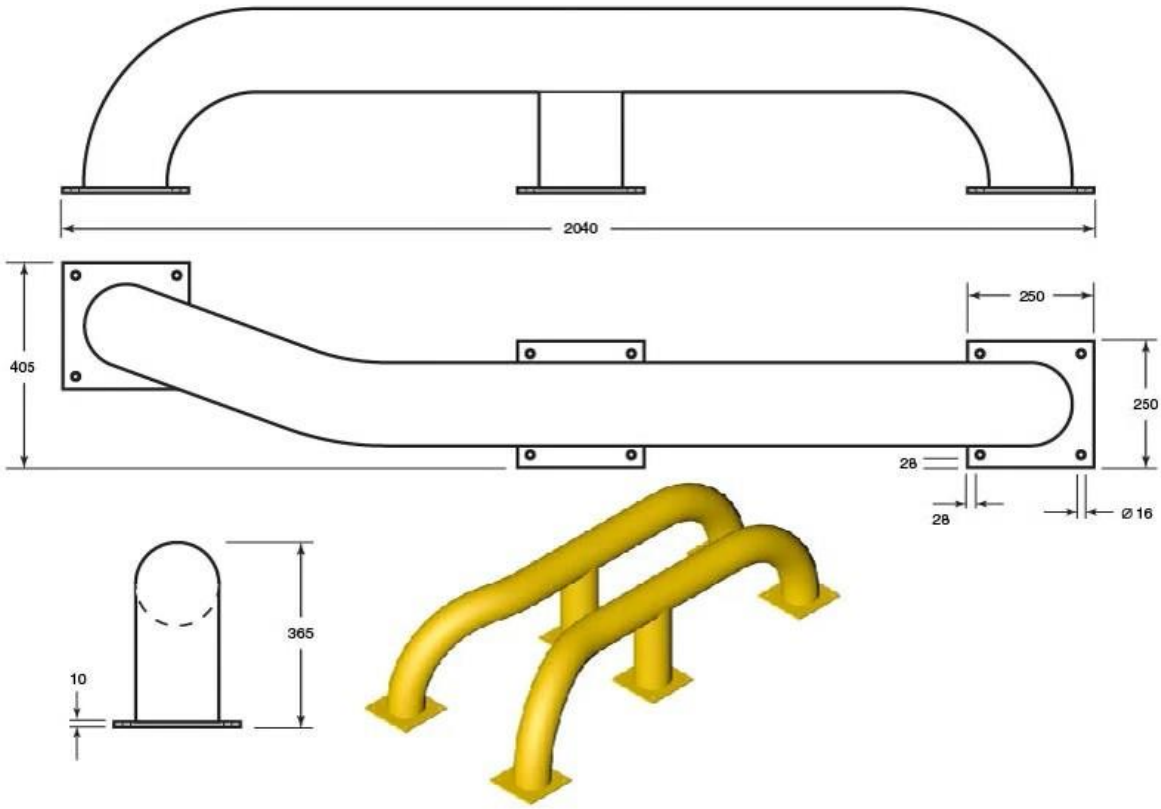

Ireland:
B2 Athy Business Campus
Athy, Co. Kildare R14 PK74
Ph: 01 531 2777
Email: sales@pittman.ie

United Kingdom:
1310 Solihull Parkway, Birmingham Business Park
Birmingham B37 7YB
Ph: 0121 630 3527
sales@pittman.uk