

TECHNICAL SPECIFICATIONS

Length: 1800 mm.

Structure: high quality cast steel, metallic grey or black finish.

Seat and backrest in exotic hardwood slats, light oak or mahogany stain finish.

Mounted on base plates.

PAINT FINISH



Black



Metallic
grey



BANC MORA

Lg.1800 : Réf.209480 - Réf.209482

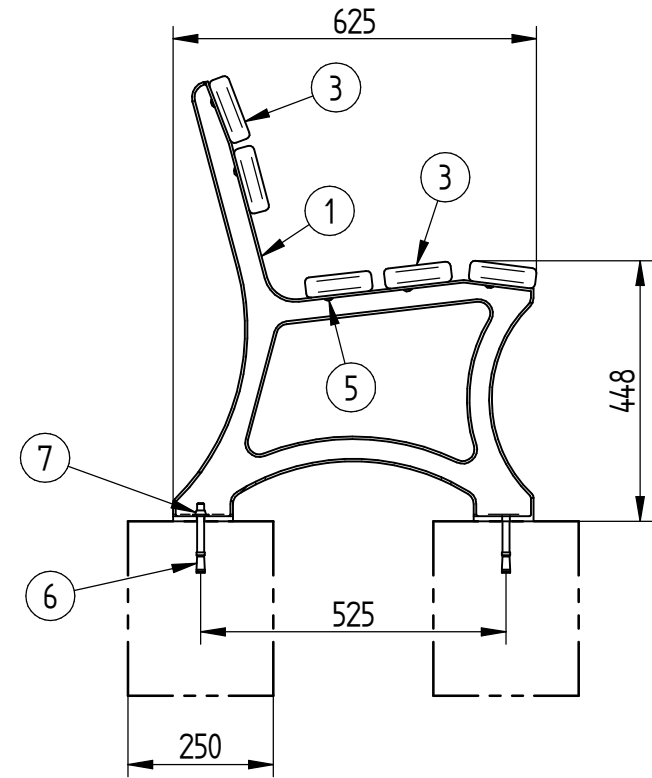
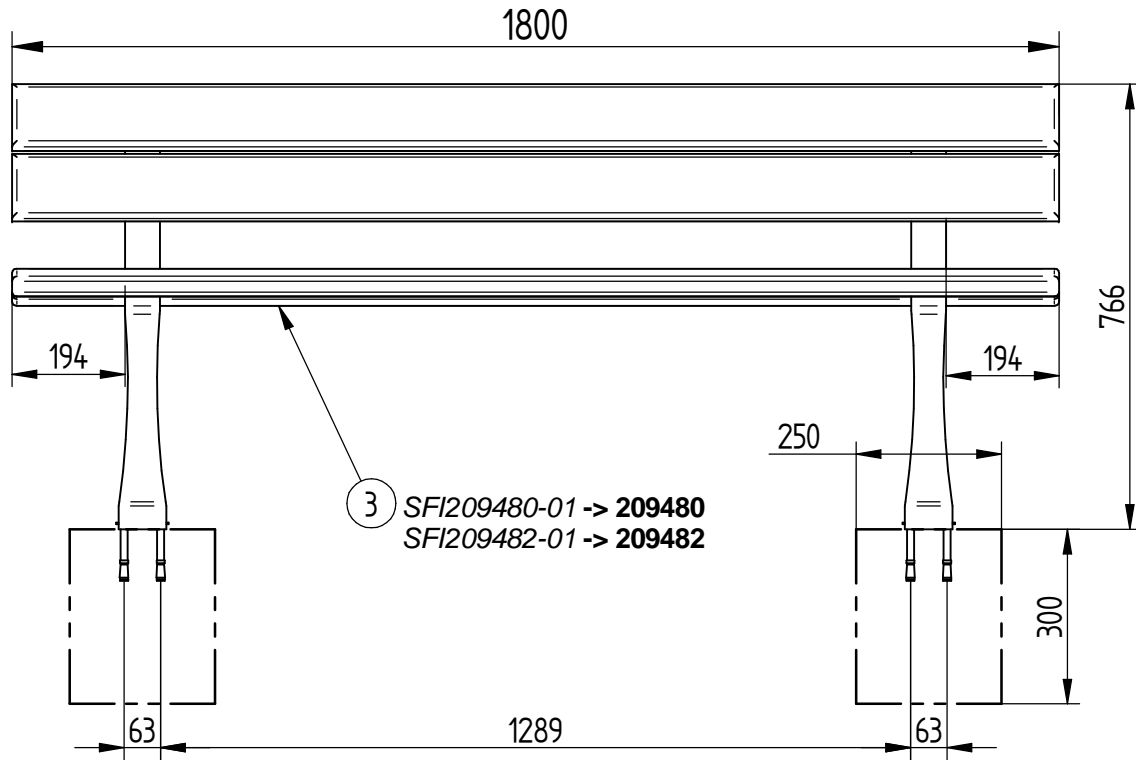

	7	ACC04999	4	Ecrou inviolable autocassant M12 A2
	6	ACC07061	4	Goujon M12x120 ZN
	5	ACC224010	20	Vis de Penture Φ 6x35 Inox A2
	3		5	LAME DE BOIS ASSISE & DOSSIER BANC MORA
	1	MFB19079	2	PIED DE BANC MORA
X	N°	Références	Qté	Description

