



BLACK BULL HEAVY DUTY RAILING SYSTEM - INDOOR

pittman[®]

OVERVIEW

The Heavy Duty Railing System is designed to provide reliable protection in busy indoor environments where pedestrian and vehicle segregation is essential. Combining heavy-duty posts, lateral rails, matching bollards, and optional access gates, it offers a robust solution for protecting people, equipment, and infrastructure in warehouses, factories, and industrial facilities.

Its durable steel construction is built to withstand frequent impacts from forklifts, pallet trucks, and other warehouse traffic, while the high-visibility powder-coated finish enhances workplace safety and provides a tough, low-maintenance barrier system.

Designed with a modular configuration, the system can be tailored to suit a wide range of layouts and applications, with optional gates, matching bollards, and flexible mounting pads available to meet specific operational and safety requirements.

FEATURES

- Heavy-duty steel construction provides reliable protection in demanding indoor environments.
- Modular design allows quick installation and flexible layouts to suit any workspace.
- High-visibility powder-coated finish improves safety while offering lasting durability.
- Compatible with gates, bollards, and flexible mounting pads for customised applications.

TECHNICAL DATA



SPECIFICATION

Product Code	SKU: 765104	SKU: 765097	SKU: 765095	SKU: 765083
Lenght	1000 mm	1200 mm	1500 mm	2000 mm
Width	80 mm			
Depth	120 mm			
Wall Thickness	4 mm			
Finish	Powder Coated Yellow			
Material	Galvanised Steel			

DRAWINGS

1000 mm

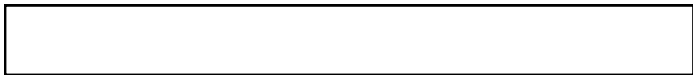

1200 mm

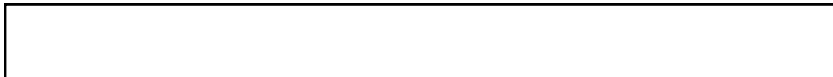

1500 mm

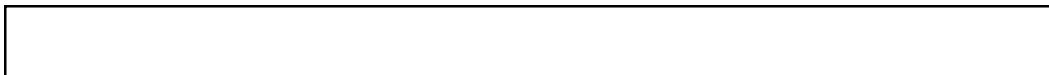

2000 mm

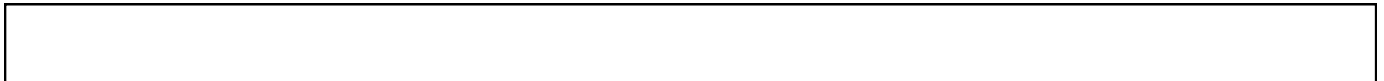

120 mm

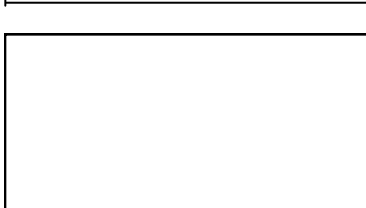

80 mm



TECHNICAL DATA



SPECIFICATION

Post Type	End Post	Middle Post	Corner Post
Product Code	SKU: 765089	SKU: 765100	SKU: 765102
Height	1000 mm		
Width x Depth	100 mm X 100 mm		
Base Plate	200 mm X 200 mm		
Base Plate Thickness	10 mm		
Finish	Powder Coated Yellow		
Material	Galvanised Steel		

DRAWINGS

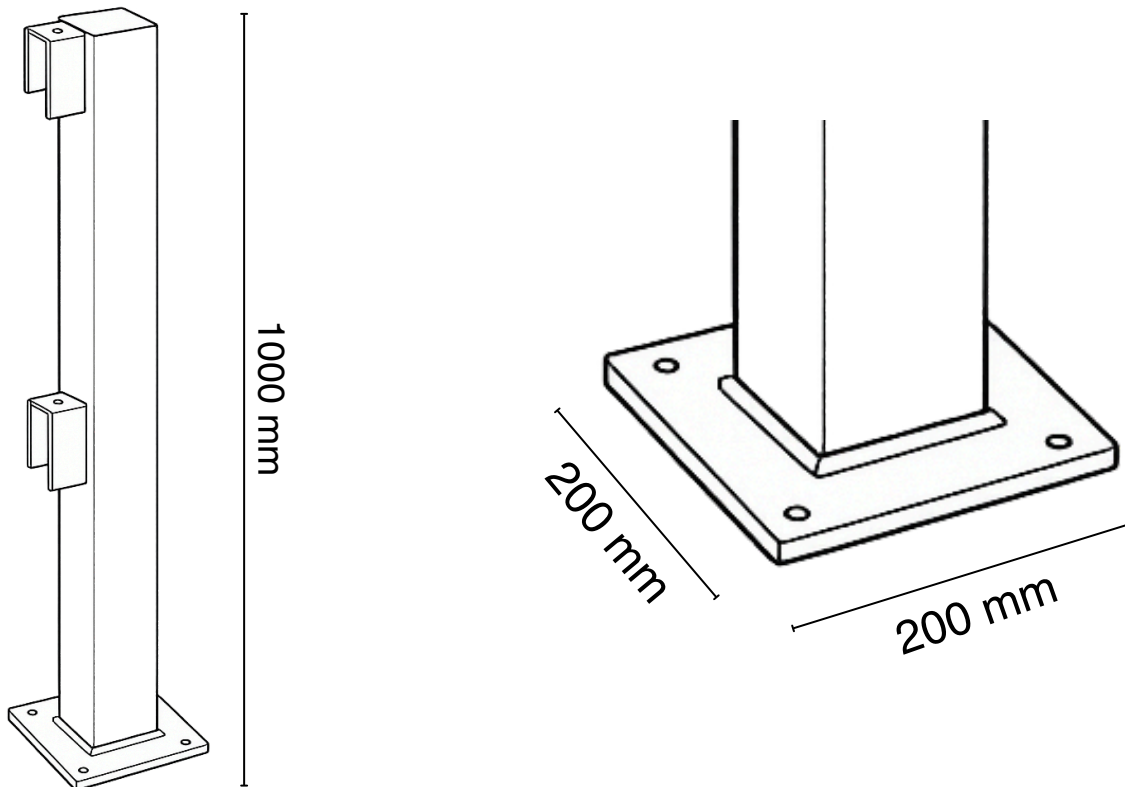

TECHNICAL DATA



SPECIFICATION

Post Type	Manual Swing Gate	Self Closing Gate
Product Code	SKU: 782653	SKU: 901621
Height	520 mm	
Lenght	905 mm	
Finish	Powder Coated Yellow	
Material	Galvanised Steel	

DRAWINGS

