



## Brooklyn Bike Shelter

Installation Guide

**pittman** | traffic & safety  
equipment

✉ [sales@pittmantraffic.com](mailto:sales@pittmantraffic.com)

☎ (01) 531 2111

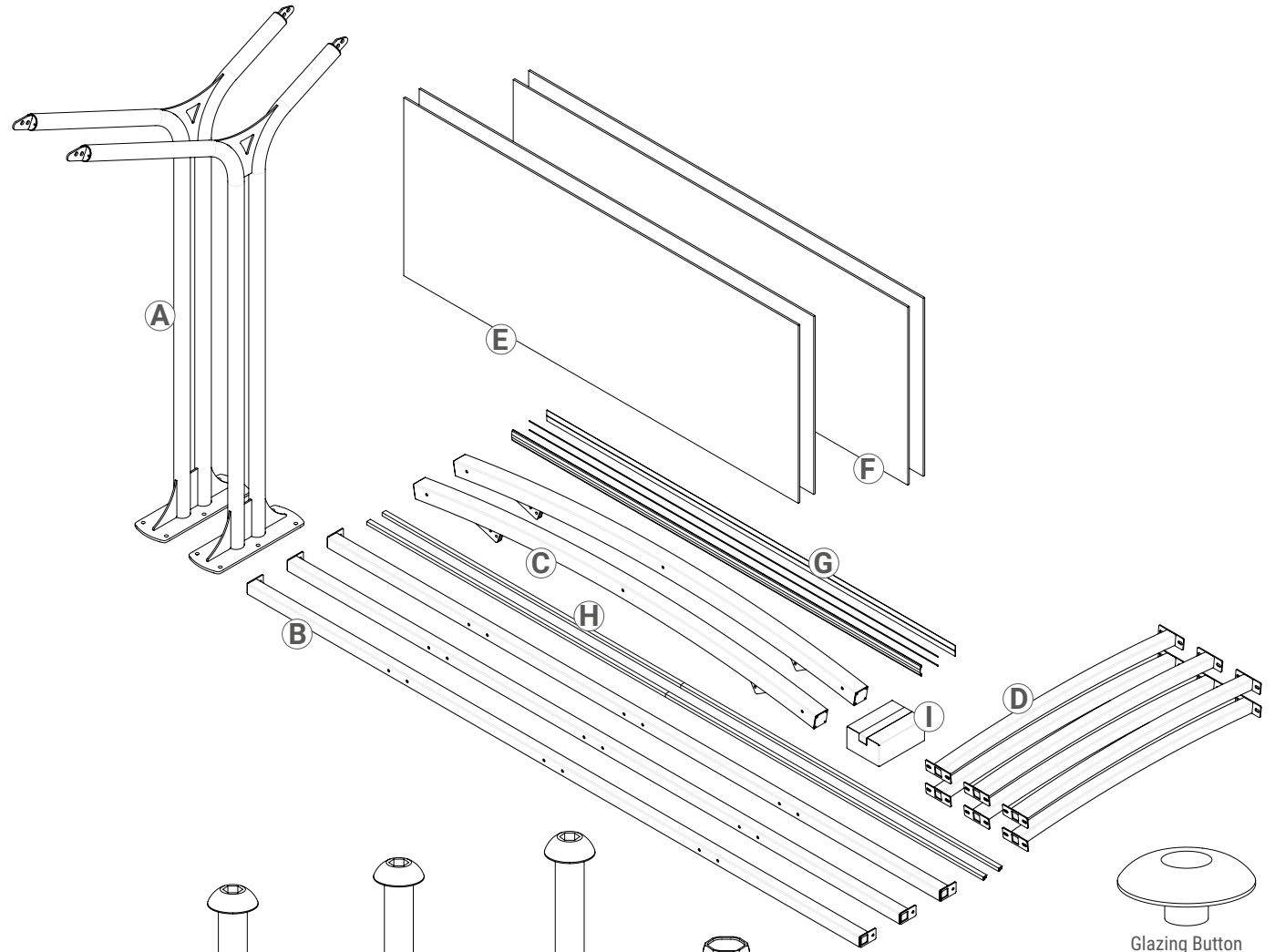

A simple shelter for bike storage, waiting area or covered outside space.

This guide will take you through:

- Delivery & site preparation
- Assembly & alignment
- Finishing & after-care

It is the customer's responsibility to make a **full visual inspection of all components** on delivery.

This document is intended to be printed A4.

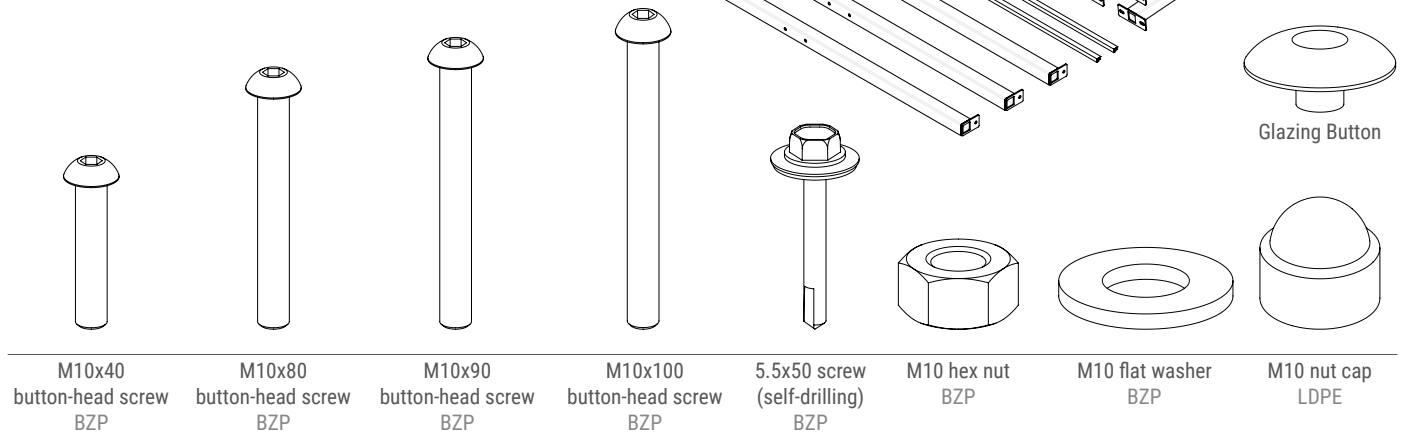



## Components

(All shelters provided with full component list specific to delivery)

- A - End Frame
- B - Purlin
- C - Roof Arc
- D - Trimmer
- E - Outer Glazing Panel
- F - Inner Glazing Panel
- G - 3-part Glazing Component (Gasket, Bead, Cap)
- H - U-Profile Roofing Trim
- I - Fixings Pack

### Fixings Supplied:

(Number supplied dependent on size of shelter)

- 1 - M10x40 Button-head Screws
- 2 - M10x80 Button-head Screws
- 3 - M10x90 Button-head Screws
- 4 - M10x100 Button-head Screws
- 5 - M10x110 Button-head Screws (Multi-bay shelters only)
- 6 - 5.5x50 Self-Drilling Screws
- 7 - M10 Hex Nuts
- 8 - M10 Flat Washers
- 10 - M10 Nut Caps
- 11 - Glazing Buttons



## Recommended Tools

For shelter assembly:

- Impact driver
- Corded/portable drill
- 8mm driver sockets (for M5)
- 17mm driver sockets (for M10)
- Adjustable wrench
- 3mm HSS drill bit
- 8mm HSS drill bit
- 13mm HSS drill bit
- Rubber Mallet
- Hacksaw
- Sharp utility knife
- Bubble/laser level
- String/laser line
- Tape/laser measure
- Soft-faced quick-release clamps
- Thread-locking compound
- Clear grease
- Clean, dry cloths

For anchoring:

- SDS Drill
- Masonry bits (to suit site-specified fixings, supplied by others)



## Safe Assembly & Handling

Recommended PPE:

- Hi-vis jacket
- Steel-toe footwear
- Eye & ear protection
- Anti-cut work gloves
- Hard hat

Brooklyn components are heavy and may have sharp edges left over from fabrication processes. As there will be heavy components over head height a hard hat is strongly recommended.

Installing Brooklyn shelters is deemed to be low-risk but please remain diligent to avoid unnecessary accidents & injury.

**You will need a minimum two persons to install a Brooklyn shelter.**

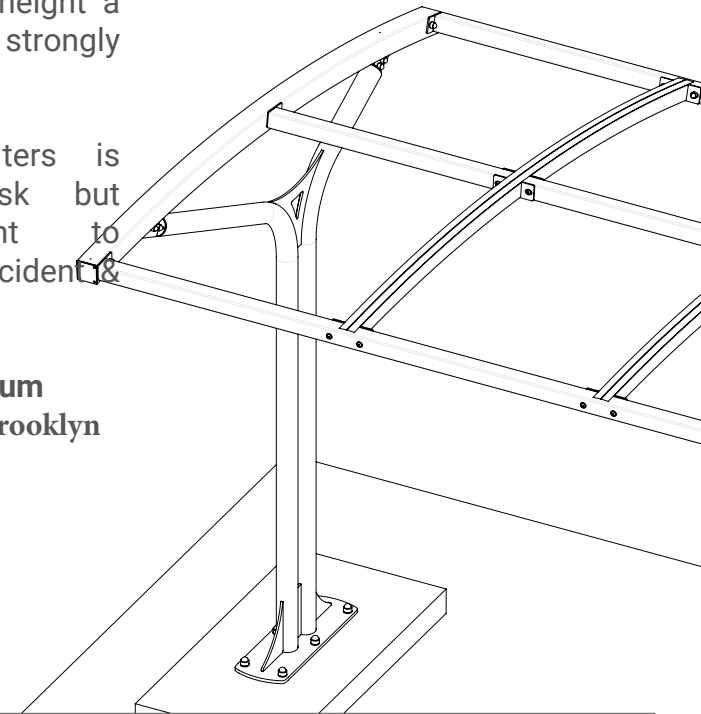

# 01

## Site Preparation

Before Brooklyn shelter delivery:

- All groundworks must be complete and spoil removed from site
- Any foundations specified by site engineer must be cast, set and levelled.
- Final installation location swept free of debris to avoid foreign object damage.

We recommend that you mark out the approximate location of the legs based on your approved General Arrangement drawing.

When starting installation it is a good idea to lay out tools and fixings, and arrange all components close to their final locations.



Foundation recommended maximum tolerance is 5mm over 3000mm distance. Anything greater may compromise quality of installation and mechanical integrity of product

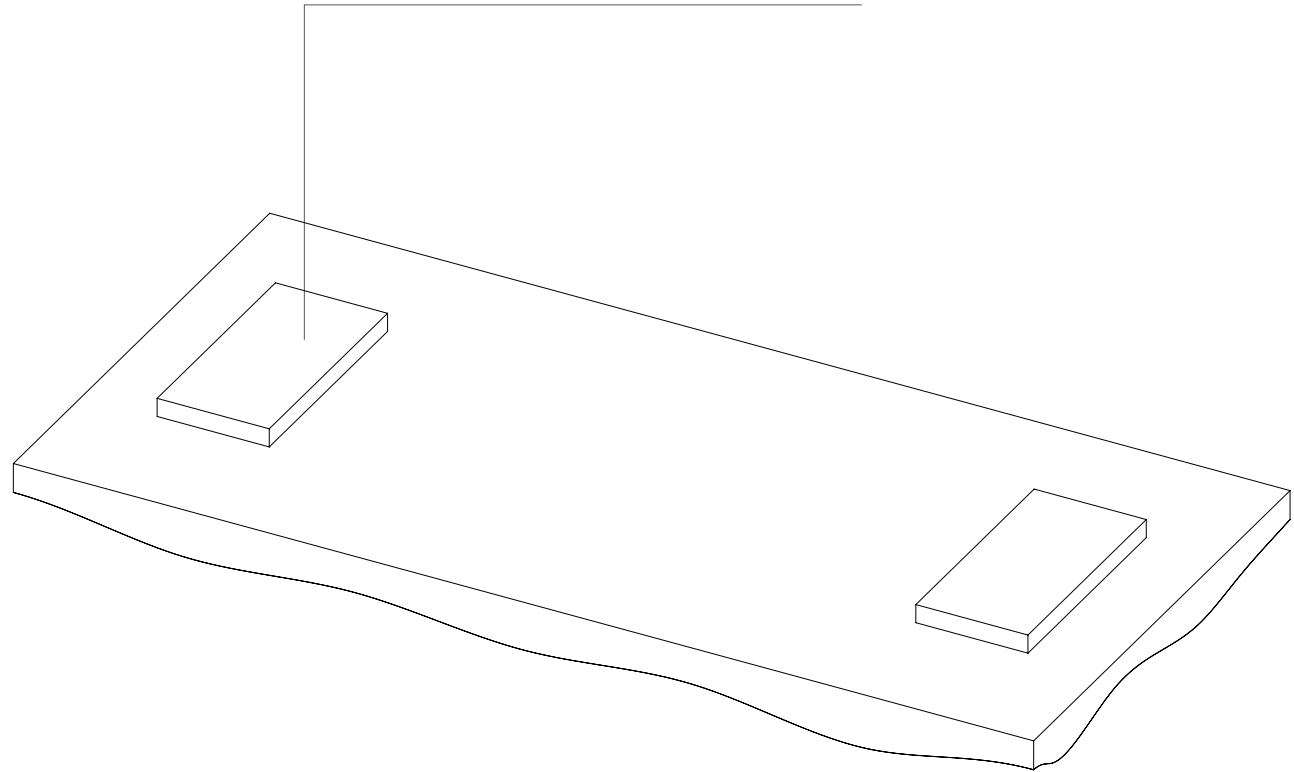

End Frames & Purlins

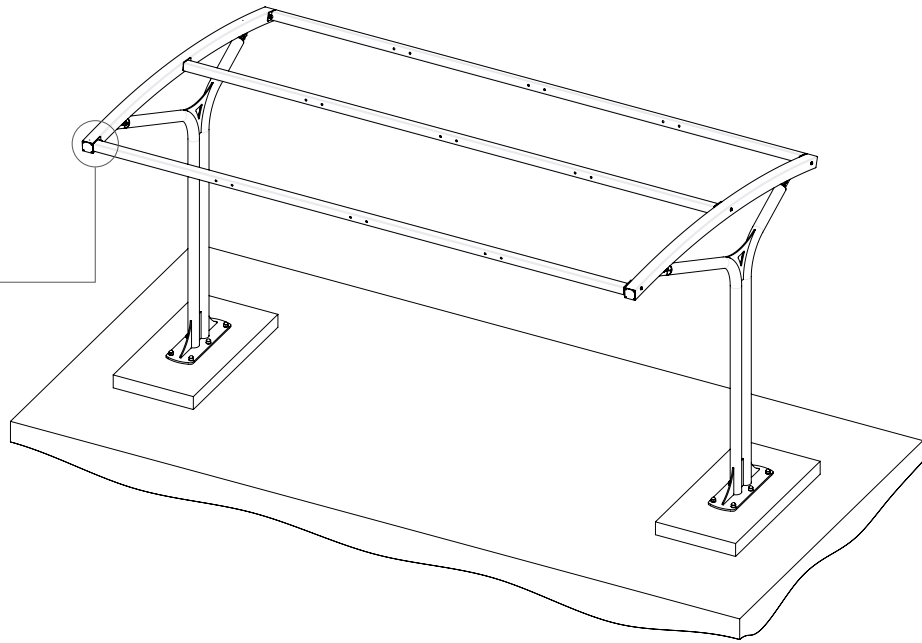
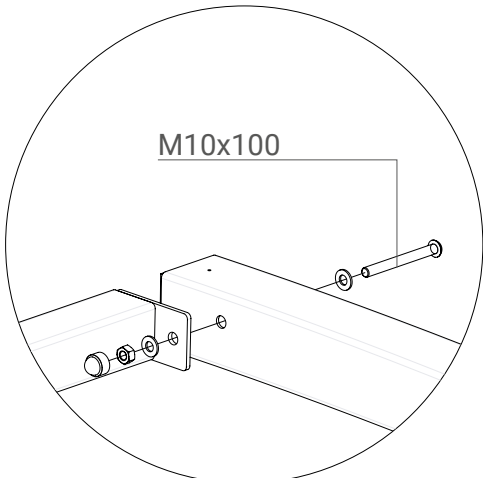
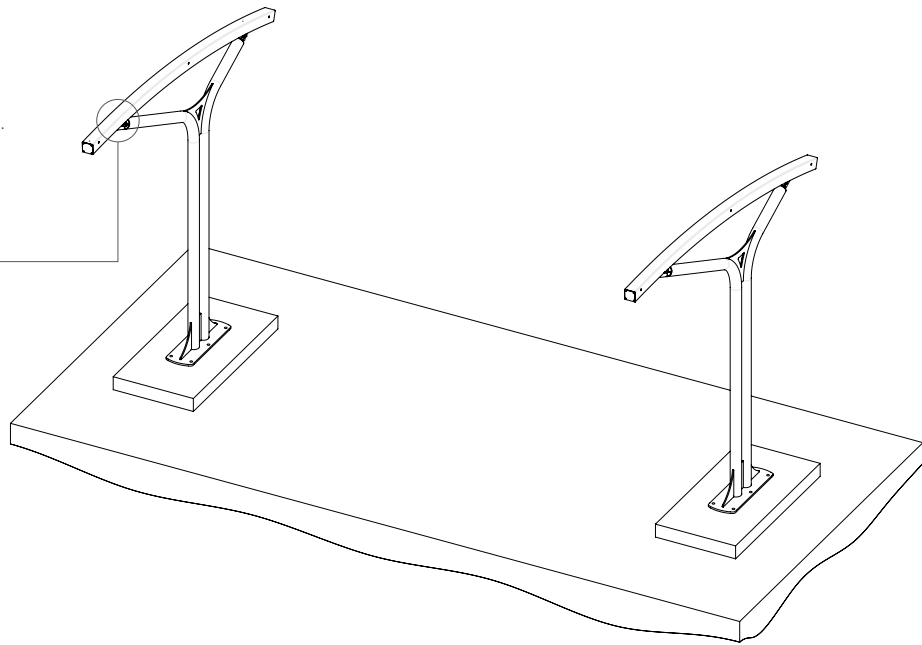
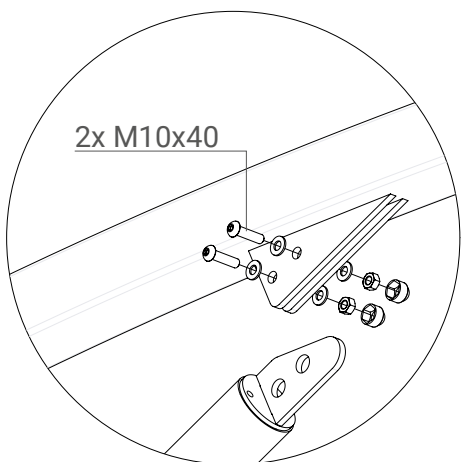

1. Assemble **legs & roof arcs** via **M10x40 screw with nut, 2x washers & LDPE caps**
2. Bolt **purlins** into **roof arc** via 1x **M10x100 screw with nut, 2x washers & LDPE cap** each end. Note correct orientation of purlin connections
3. Once **leg** spacing is set by fixed length of **purlins** ensure legs are square and vertical

Ensure loose structure is well supported during initial assembly steps

Fixings only tight enough to support structure at this stage.

Thread-locking compound must be applied to all fixings.





## Anchoring & Trimmers

- Starting at one corner, use the **leg's footplate** as a template for pre-drilling foundations for site-specified anchoring fixings
- Connect **trimmers** to outer **purlins** via **M10x80 screw with nut, 2x washers & LDPE caps**
- Connect **trimmers** through central **purlin** via **M10x90 screw with nut, 2x washers & LDPE caps**
- Adjust full roof structure for squareness and alignment and then tighten to appropriate torque

**Thread-locking compound must be applied to all fixings.**

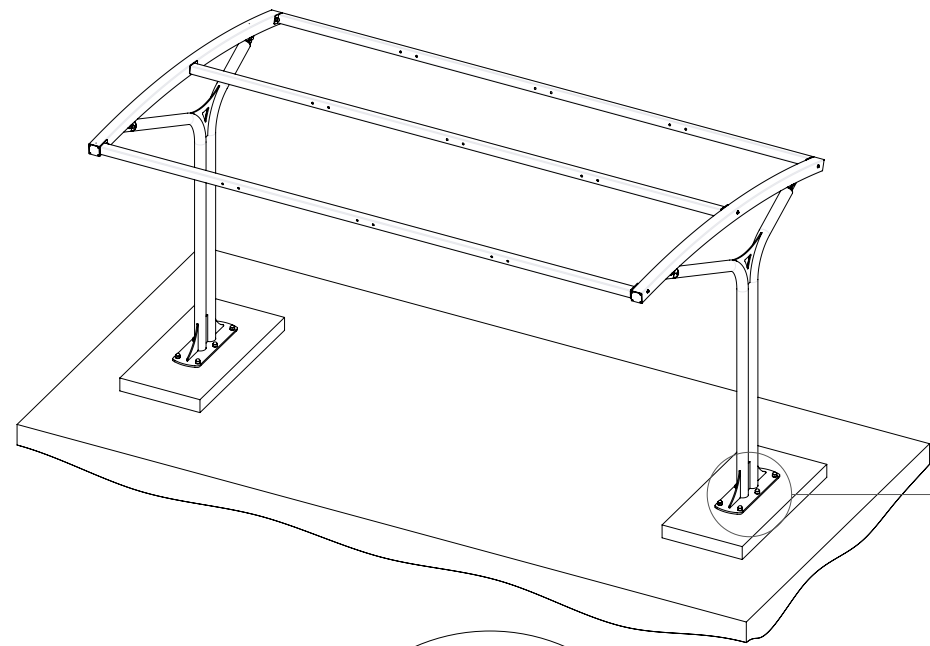

Anchoring fixings must be specified by site engineer based on local ground conditions and supplied by others. Throughbolts shown as example only.

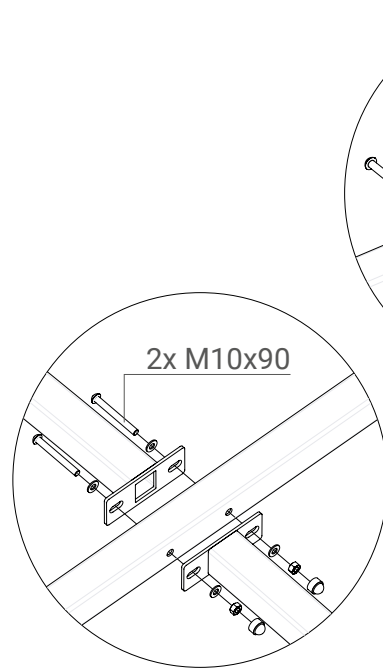

For Brooklyn shelters with bays over 4.0m wide, 4 pairs of trimmers will be supplied per bay.

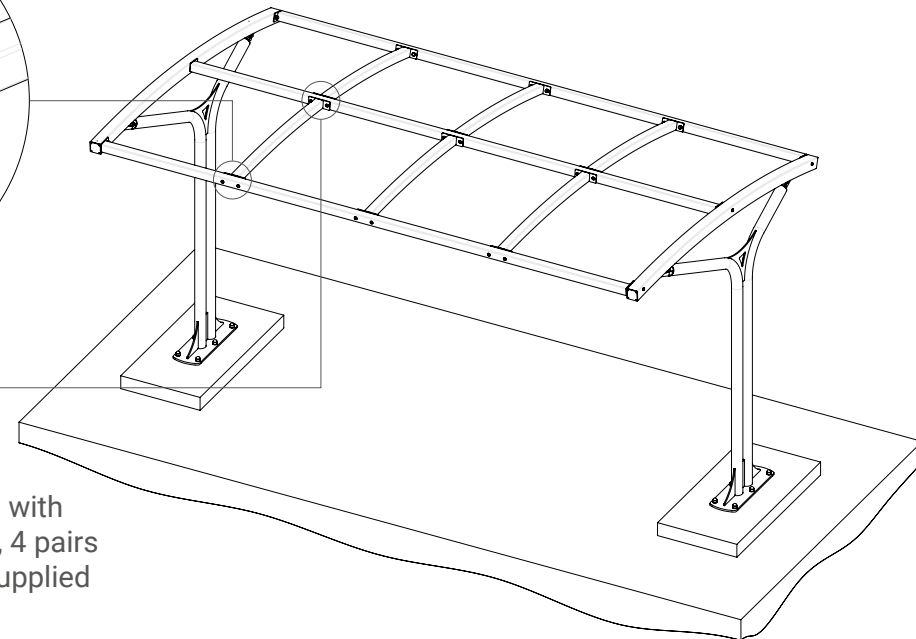

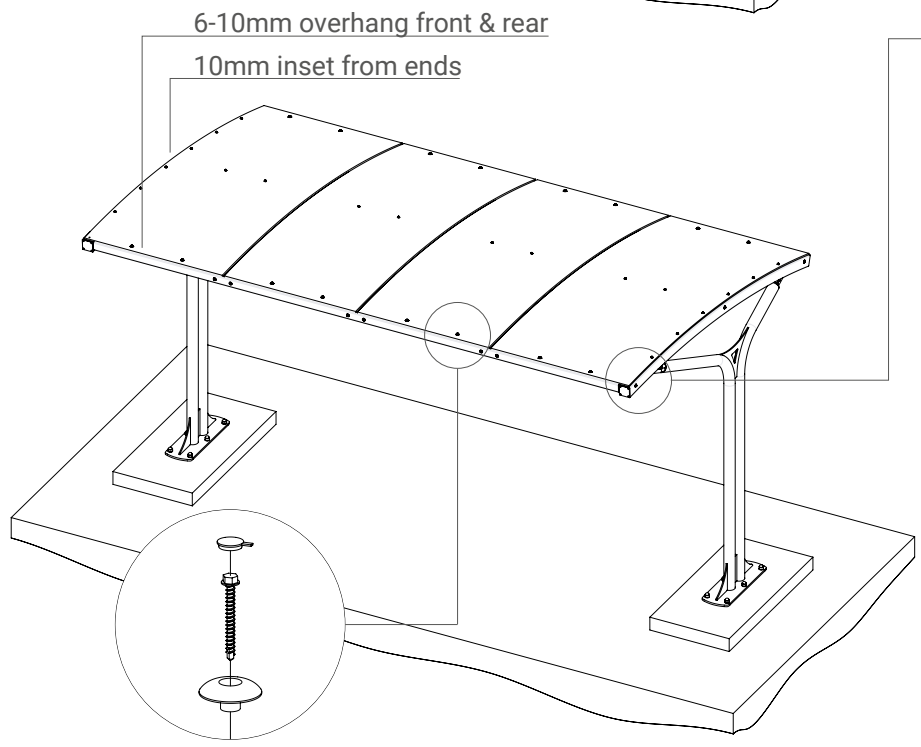
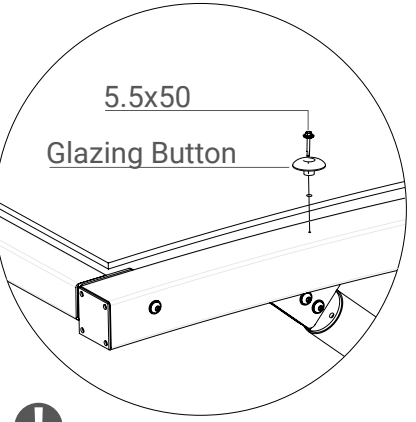
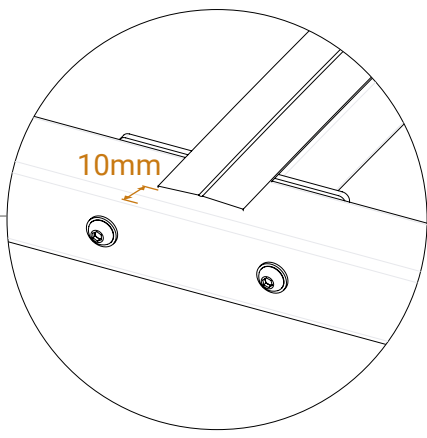
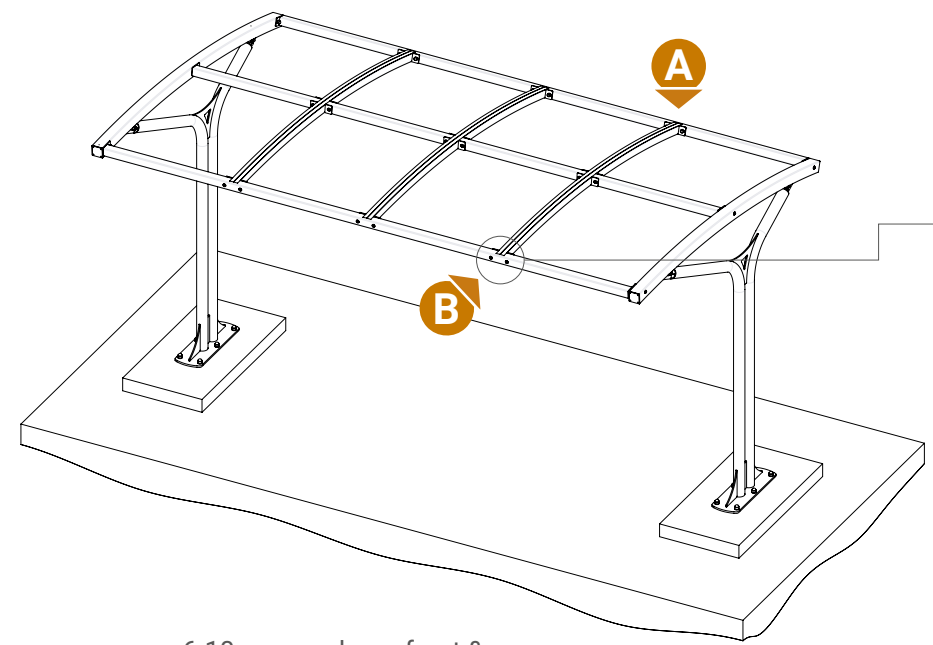

8. Lay a length of gasket strip across all **trimmers** and intermediate **frames** (for multi-bay shelters) from point **(A)** to **(B)**. Make sure the gasket starts and ends 10mm in from the outer steelwork faces. **End frames** do not require gasket strip

9. Pre-drill 3mm holes in all glazing faces of the structure. Holes should run along the centreline of each steel member min. 30mm from the end and then every 300mm. In **purlins** drill 2x holes equally spaced between each set of trimmers as shown

Holes should be cleared of swarf and de-burred/lightly countersunk, and then a small amount of clear grease applied inside the hole, and wiped clear of the glazing face

**!** Pre-drill 8mm holes in roofing sheet to allow adjustment and accommodate expansion and contraction of plastic.

Ensure gap of 12-16mm between roofing sheets.

It may help to clamp **roofing sheets** in place using soft-face, quick release clamps.

For added protection, use a small amount of silicone sealant around the glazing buttons.

10. Peel back protective film min. 80mm from all edges and carefully pull 1x **roofing sheet** up onto the structure

Ensure **roofing sheet** is set approximately 10mm in from outer face of **end frames**, and overhangs front and rear by approx. 8mm

11. Pre-drill **roofing sheet** to 8mm aligned with pilot holes in steelwork. Fix roofing to roof arc & central purlin only via 5.5x50mm self-drilling screw with glazing button and cap

## Glazing continued

12. Push-fit **aluminium U-profiles** onto front and rear of glazing sheets, across width of shelter roof, with 6mm **drip channel** of profile facing down and lipping over edge of the roof. U-profile will be cut to length prior to delivery
13. Pre-drill **roofing sheet** directly behind **U-profile** to 8mm aligned with pilot holes in steelwork.
14. Insert **glazing cap bead** into **aluminium glazing cap profile**
15. Locate **glazing cap** centrally over **trimmers** and within space between **aluminium U-profile trims**. Glazing caps may need cutting to length
16. Starting at top, set 30mm in from front edge of **U-profile**, fix **cap** to roofing via **5.5x50mm self-drilling screws**. Locate additional 50mm screws every 300mm

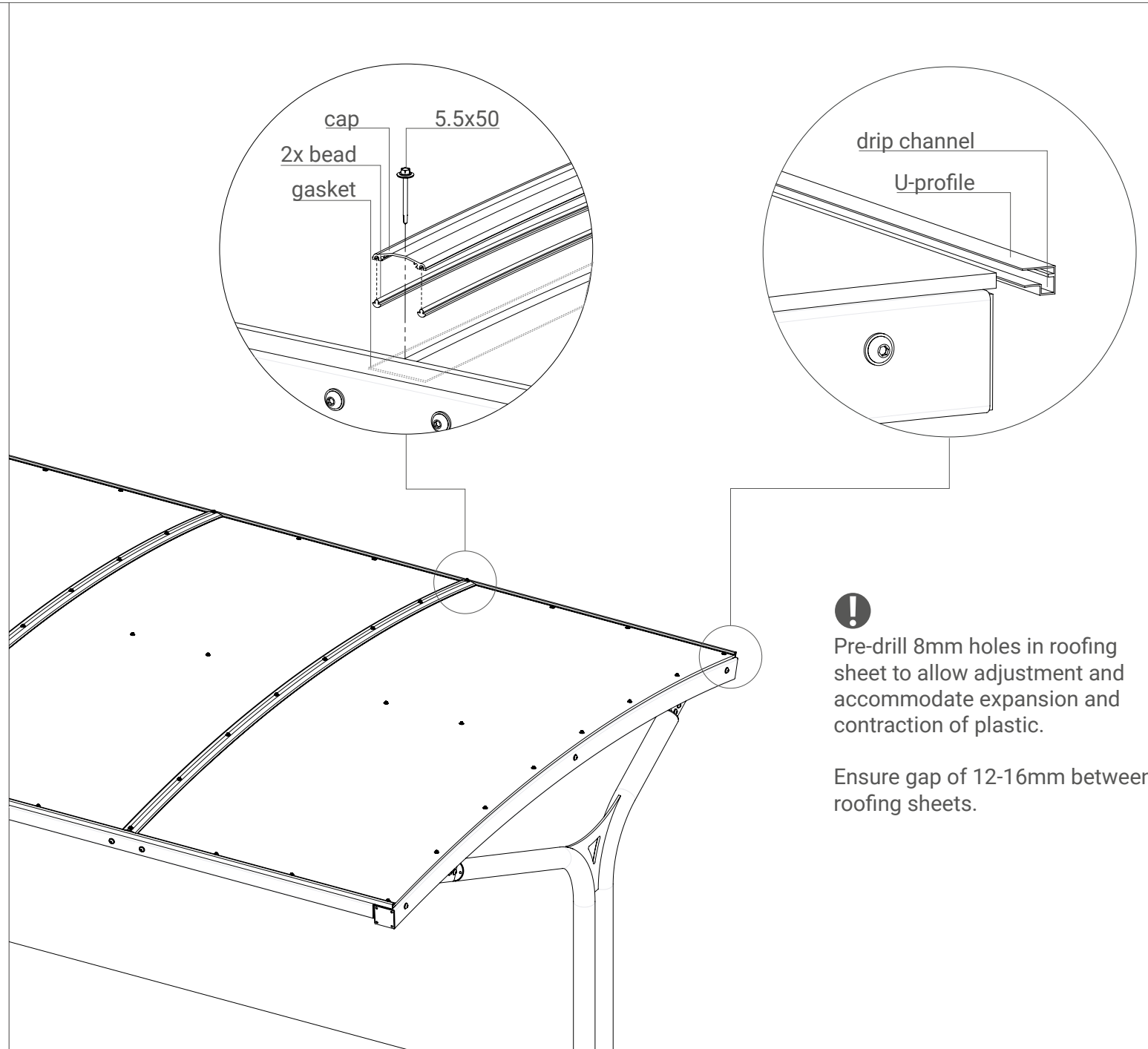



Multi-bay Shelters

**Brooklyn shelters** come in: up to 4.0m bay version with a three sets of **trimmers**, and up to 5.0m version with four sets of **trimmers**. Multiple bays can be added to create longer shelters.

- 17. Follow previous assembly steps for single bay structure assembly
- 18. Where there are adjoining roofs, replace the **M10x100 bolt** connecting the **purlin** to the **end frame**, with a **M10x110** bolt to allow a **frame** and two **purlins**
- 19. Multi bay **Brooklyn shelters** have:
  - outer roof ing sheets (A)**
  - inner roof ing sheets (B)**
  - overlap roof ing sheets (C)**
 Be sure to check and split out **inner, outer & overlap roof ing sheets** before assembly begins

**Ensure full structure is square, level and all fixings tightened to appropriate torque.**

**Remove any remaining protective film from glazing panels and clear away any dust/dirt from the plastic surfaces**

**Clean all steelwork with a damp cloth to leave Brooklyn shelter ready for handover and presentation.**

**Once complete, hand this document to the new owner of the shelter for future reference.**

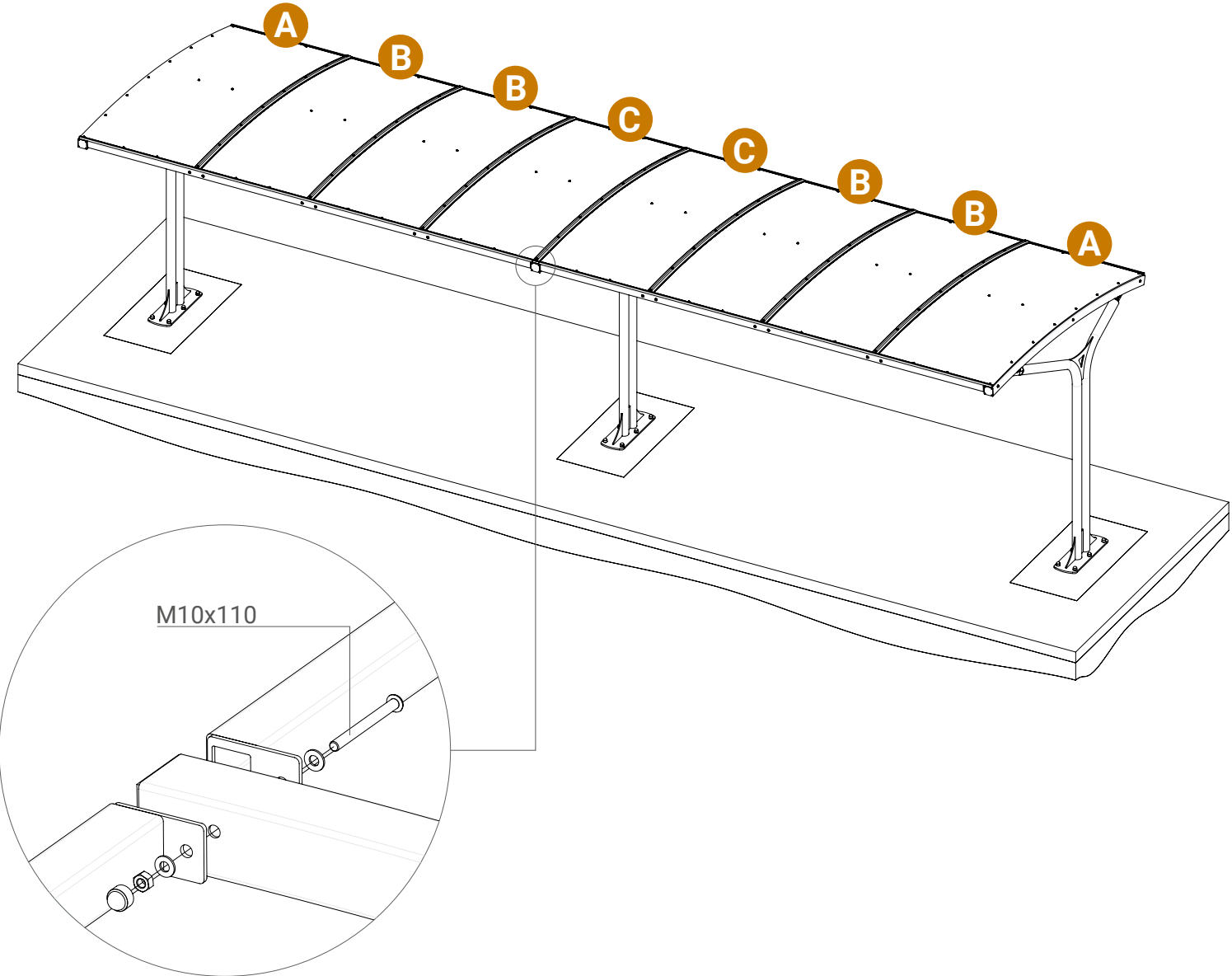

# Brooklyn Shelter maintenance

It is important to follow this guideline maintenance schedule to keep your Brooklyn shelter looking and functioning as well as it did when it was installed:



## steelwork

Galvanising & powder-coating on Brooklyn shelters is critical for prevention of premature corrosion and failure. The simplest way to avoid this is to keep visible surfaces clean and clear of damaging debris.

Schedule:

**Once per 6 month period** check all fixings for play and tighten as necessary.

**Once per 6 month period** inspect all visible surface for signs of corrosion (holes in powder coat or blistering). Any identified wear should be cleaned and touched-up with a matching spray coating.



## plastics

Once protective film on glazing is removed, the panels are prone to surface scratches, although the Polycarbonate supplied is resistant. As the roofing expands and contracts with temperature changes it is likely to move.

Schedule:

**3 months from installation** inspect all visible surfaces for bulging. You may need to remove and replace a number of screws if adequate

**Once per 6 month period** check all visible surfaces for failure (cracks/stress marks) due to improper use. If heavily cracked panels may need replacing.



