

Product Specification Sheet

Product name – Impact Recovery Systems Flex Post Delineator

Product code 737114



Manufacturer / Brand	Impact Recovery System
Warranty	1 Year manufacturer's warranty
Material	Post: Polypropylene plastic post Base: High Density Polyethylene (HDPE)
Components	Post with separate fixed base as standard
Dimensions	Post: 990(H) x Ø 60 mm (90mm wide at squeeze) Base: 200 x 200mm
Features	Highly reflective marking for better visibility Squeezed format allows more room for markings Bents on impact to reduce impact damage Comes with fixed base as standard – other base options available Easy installation – bolt down fast

Ireland:
B2 Athy Business Campus
Athy, Co. Kildare R14 PK74
Ph: 01 531 2777
Email: sales@pittman.ie

United Kingdom:
1310 Solihull Parkway, Birmingham Business Park
Birmingham B37 7YB
Ph: 0121 630 3527
sales@pittman.uk

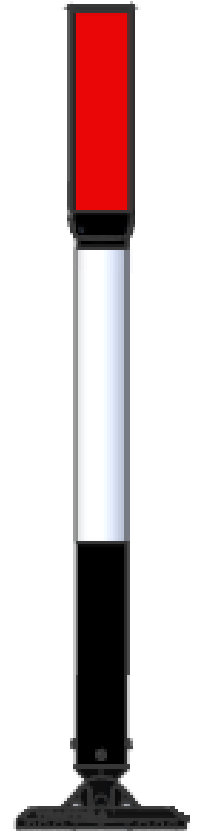
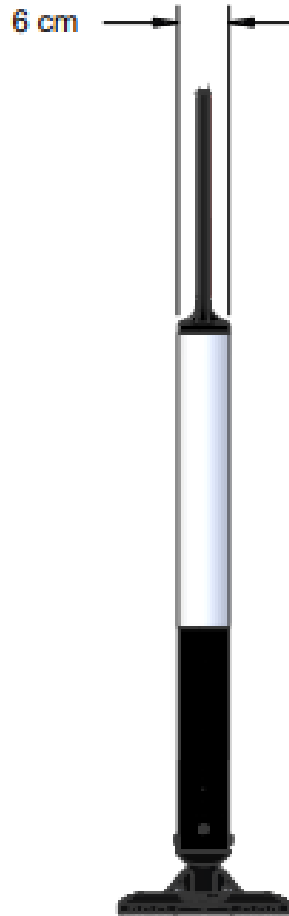
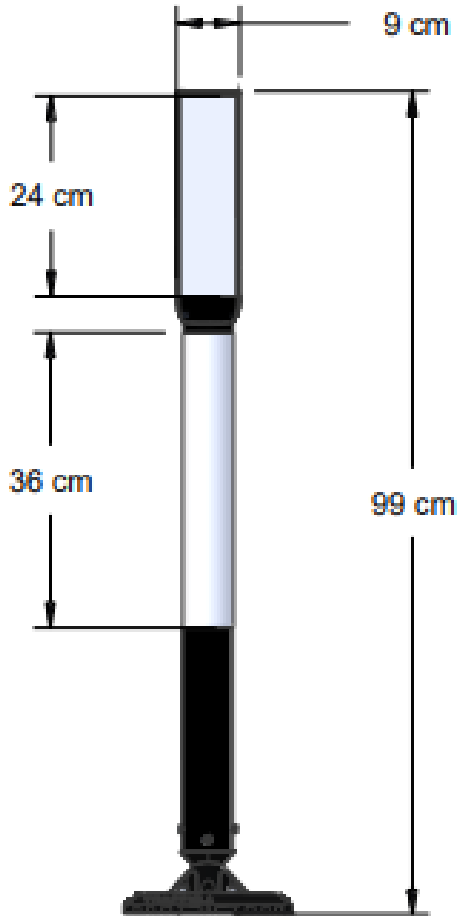

Ireland:
B2 Athy Business Campus
Athy, Co. Kildare R14 PK74
Ph: 01 531 2777
Email: sales@pittman.ie

United Kingdom:
1310 Solihull Parkway, Birmingham Business Park
Birmingham B37 7YB
Ph: 0121 630 3527
sales@pittman.uk