

1



- 1) N° NOT709
- 2) N° NOT807
- 3) N° NOT721
- 4) N° NOT723
- 5) N° NOT805
- 6) N° NOT724
- 7) N° NOT473
- 8) N° NOT474



**pittman** | traffic & safety equipment

✉ sales@pittmantraffic.com

☎ (01) 531 2111

# STATION-BUS MILAN - 5m

Poteaux 80x80, 1 Bardage de Fond, 1 Bardage Latéral  
1 Caisson, Vitrine Horaire - Réf.529231

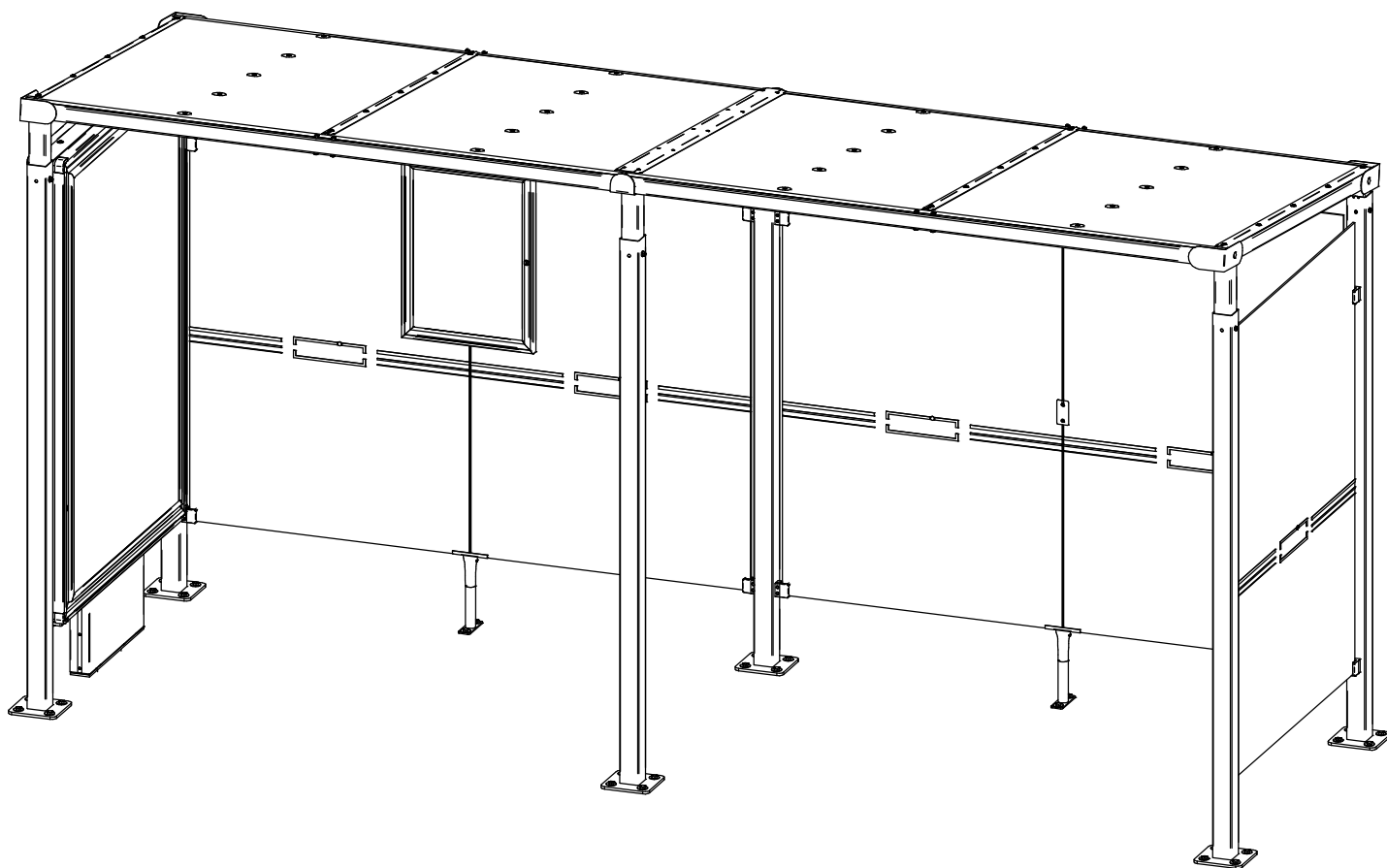

PROCITY = (x0)

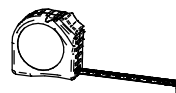
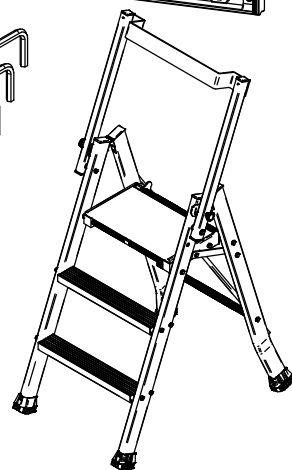
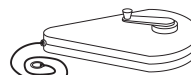
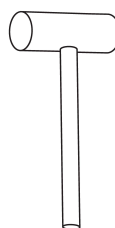
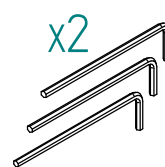
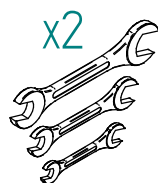
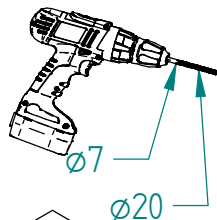
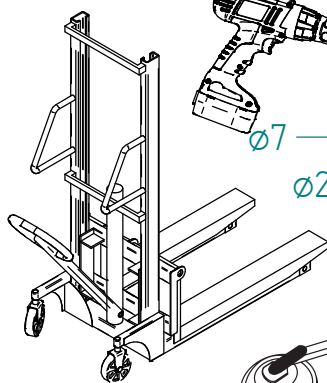
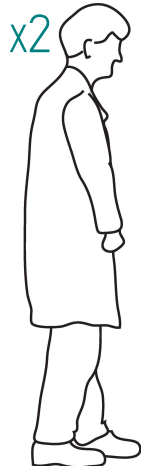

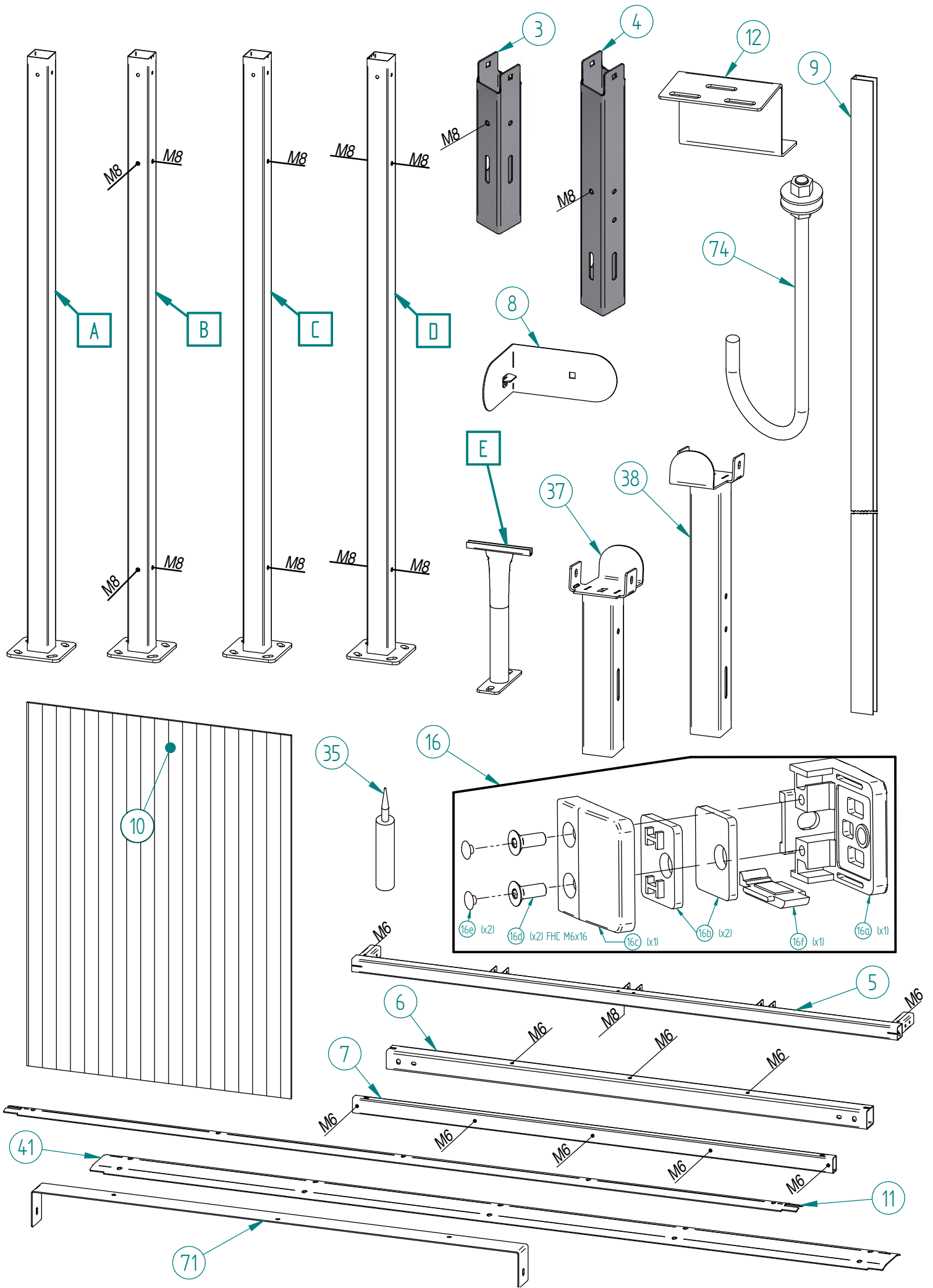

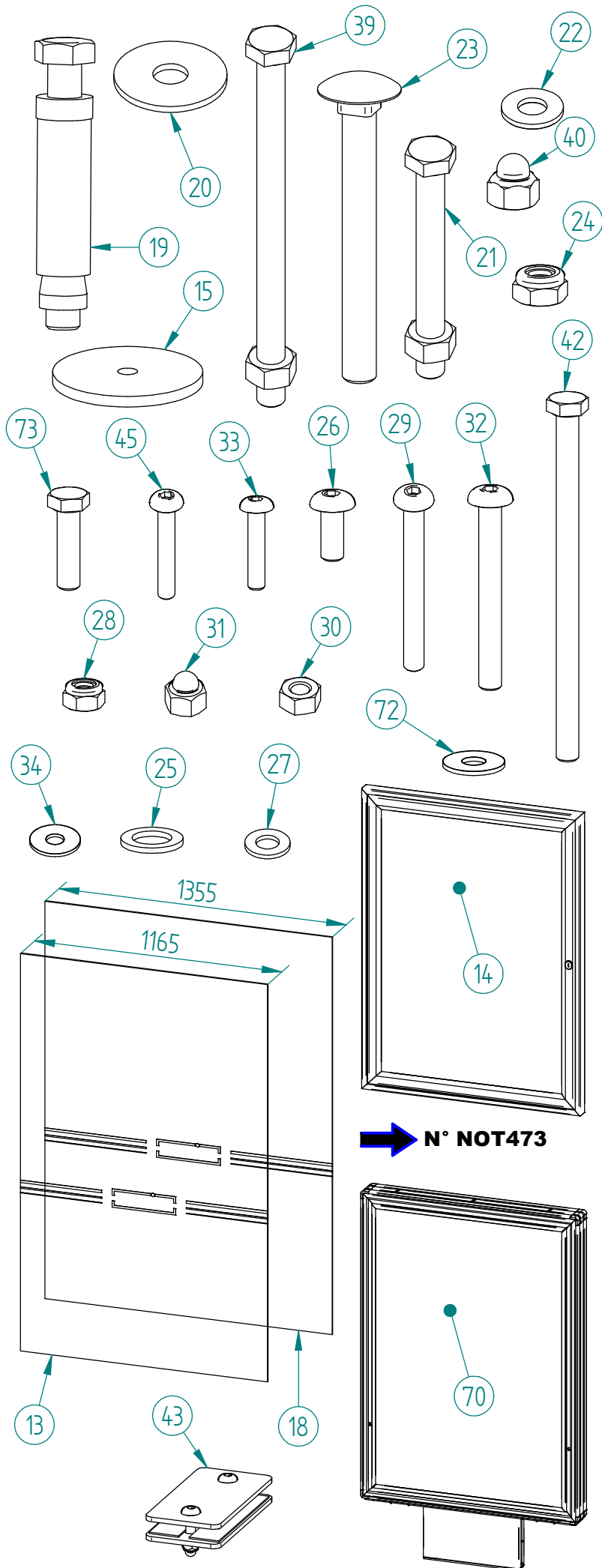

74	ACC03520	4	Crosse $\Phi$ 16x400-100 + 2 Ecrous H M16 + 2 Rondelles M16
73	ACC22061	2	Vis H M8x30 A2-70
72	ACC18118	5	Rondelle plate L8 A2
71	SFIS29230-06	1	BARRE DE FIXATION CAISSON 3000
70	508305	1	CAISSON SUR PIED CENTRAL VIP LUMINEUX
45	ACC22035	20	Vis BHC M6x40 Inox A2-70
43	SFIS29301-B	1	PINCE ENTRE VITRAGE
42	ACC22050	2	Vis H M8x130 Inox A2-70
41	SFIS29241-03	1	TOLE DE LIAISON INITIAL/COMPLEMENTAIRE
40	ACC04987	2	Ecrou Borgne Frein M10 Bague Nylon - A2
39	ACC02157	2	Boulon H M10x150 - ZN
38	SFIS29241-B	1	SUPPORT DE TOIT CENTRAL AVANT
37	SFIS29241-A	1	SUPPORT DE TOIT CENTRAL ARRIERE
35	ACC19111	1	SILICONE TRANSLUCIDE
34	ACC18081	30	Rondelle Plate $\Phi$ 6L A2
33	ACC220216	30	Vis BHC M6x30 Inox A2-70
32	ACC22185	20	Vis BHC M8x70 A2-70
31	ACC04986	26	Ecrou M8 Frein Borgne A2-70
30	ACC05012	4	Ecrou H M8 A2
29	ACC02144	4	Vis BHC M8x80 A2-70
28	ACC04981	4	Ecrou M8 frein bague nylon A2
27	ACC18145	60	Rondelle M8N
26	ACC22226	23	Vis BHC M8x20 A2-70
25	ACC18120	4	Rondelle Plastique $\Phi$ 14,1x $\Phi$ 22x2
24	ACC05038	4	Ecrou frein M10 Inox
23	ACC220362	4	Vis RCC M10x90 Inox A2-70
22	ACC18143	14	Rondelle M10 - ZN
21	ACC02174	6	Boulon H M10x90 - ZN
20	ACC18130	28	Rondelle large LL12 A2-70
19	ACC03322	28	Cheville à expansion M12
18	VIT81125-02	1	VERRE SECURIT 1860x1355
16	ACC16127	16	PINCE A VERRE AVEC SABOT
15	ACC529260-01	20	ATTACHE ALVEOLAIRE $\Phi$ 53
14	505045	1	VITRINE HORAIRE Ht.750x550
13	VIT81108-02	4	VERRE SECURIT 1860x1165
12	SFIS29240-05	2	PATTE DE FIXATION BARDAGE VERRE DE FOND
11	SFIS29240-04	4	TOLE DE FIXATION ALVEOLAIRE Lg.1650
10	SFIS29240-03	4	ALVEOLAIRE DE TOITURE 1210x1650x10
9	SFIS29255-J	4	U POUR ALVEOLAIRE Lg.2498 AVEC JOINT
8	SFIS29255-E	4	TOLE DE FINITION D'ANGLE AVEC CALE
7	SFIS29240-D	6	TRAVERSE CENTRALE EQUIPEE
6	SFIS29240-C	4	TRAVERSE D'EXTREMITE EQUIPEE AVEC INSERTS
5	SFIS29255-R	4	POUTRE EQUIPEE POUR ABRI MILAN
4	SFIS29255-Q	2	SUPPORT DE TOIT AVANT EQUIPE
3	SFIS29255-P	2	SUPPORT DE TOIT ARRIERE EQUIPE
<b>E</b>	SFIS29300-14	2	PIED POUR BARDAGE DE STATION BUS
<b>D</b>	SFIS29309_14	1	POTEAUX 80x80 Lg.2260 + 4 FIXATIONS A 180°
<b>C</b>	SFIS29309_12	2	POTEAUX 80x80 Lg.2260 + 2 FIXATIONS
<b>B</b>	SFIS29309_13	1	POTEAUX 80x80 Lg.2260 + 4 FIXATIONS A 90°
<b>A</b>	ATE529308-A	2	POTEAUX 80x80 Lg.2260 SANS FIXATIONS
X	N°	Références	Qté Description

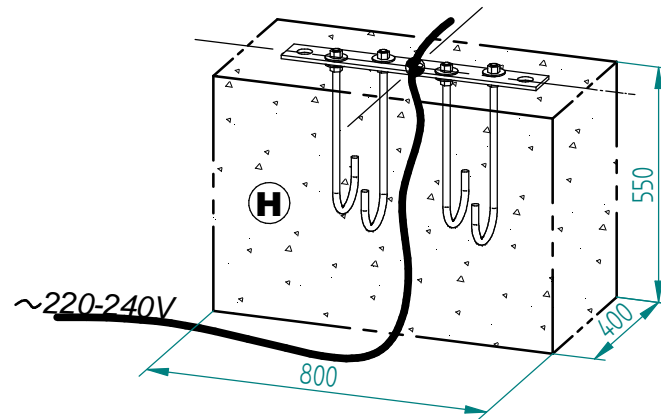
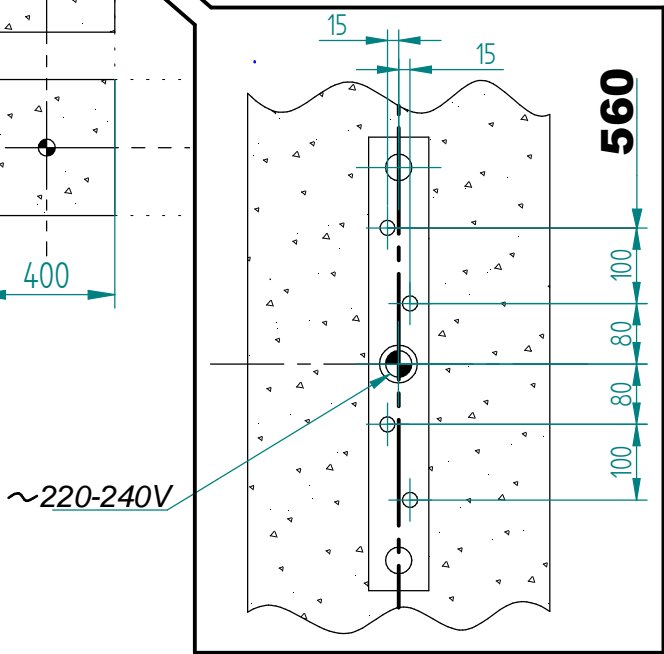
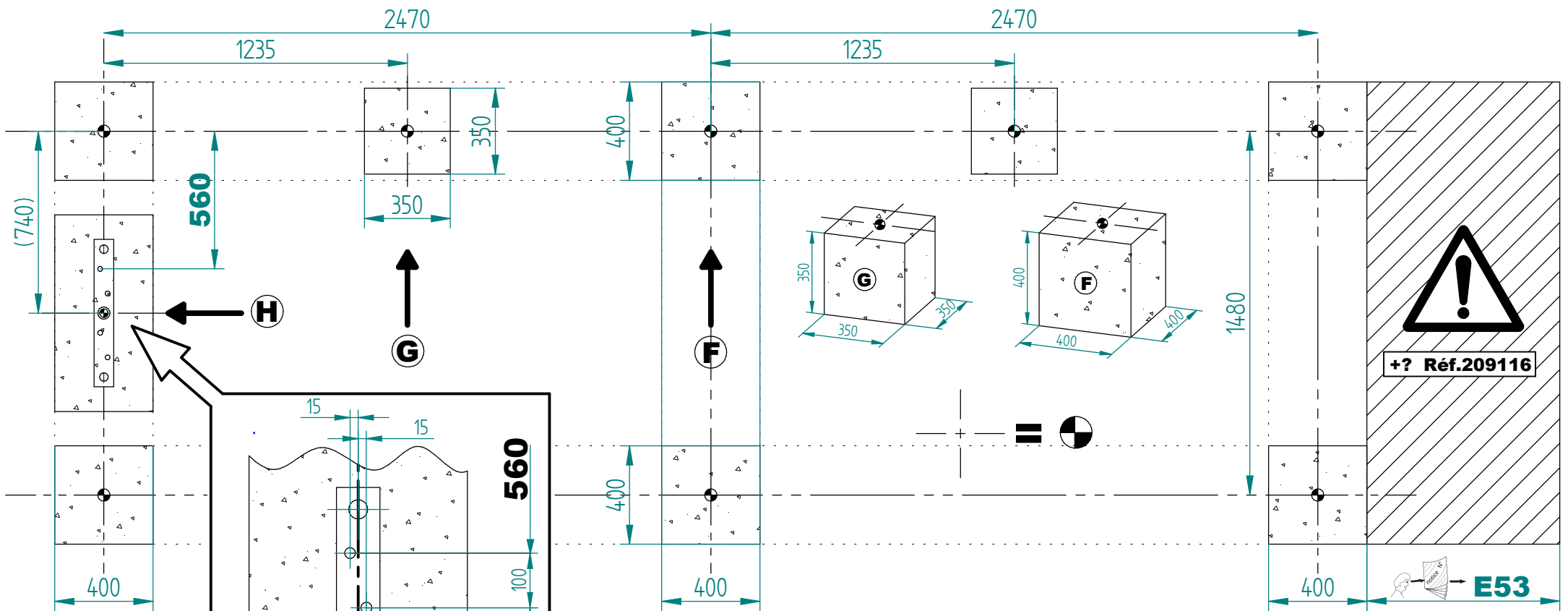

**E53**

# Montage Bardage

## ABRI & STATION-BUS MILAN

1

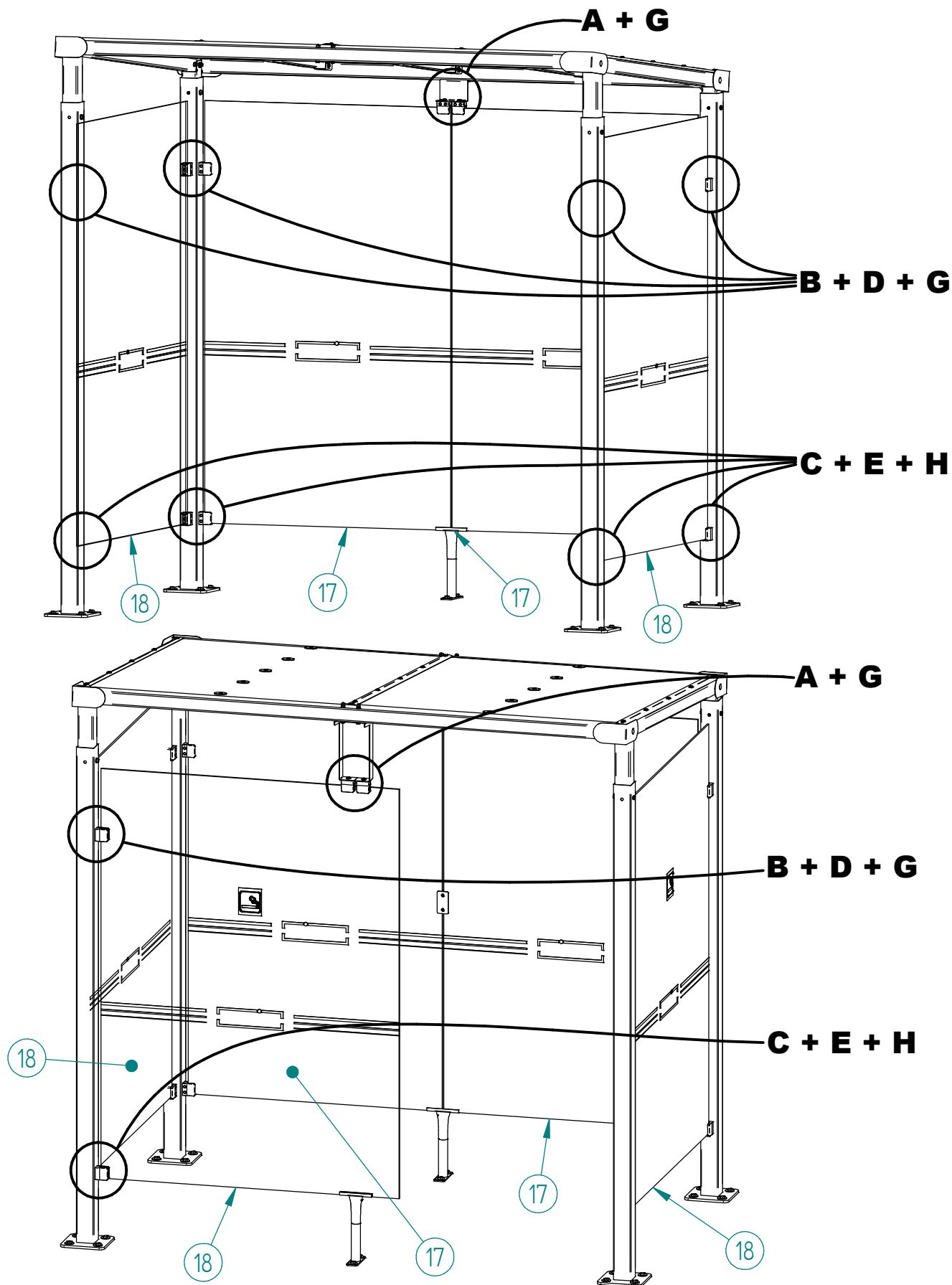

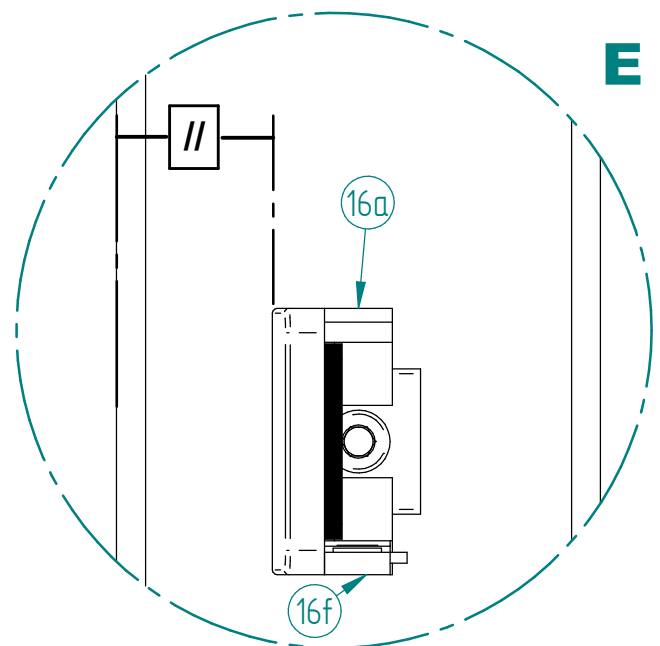
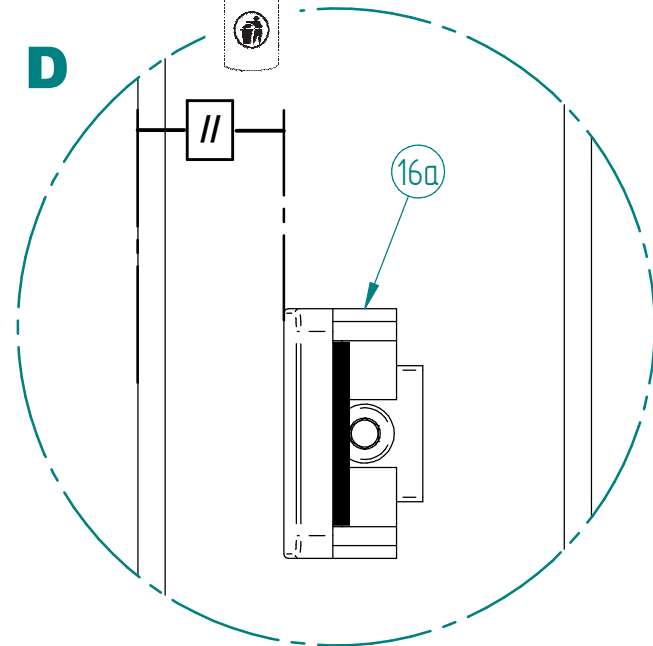
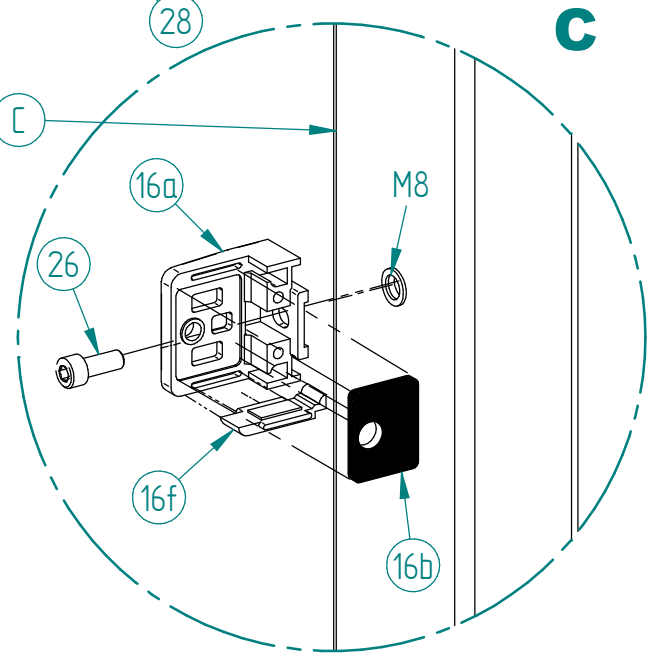
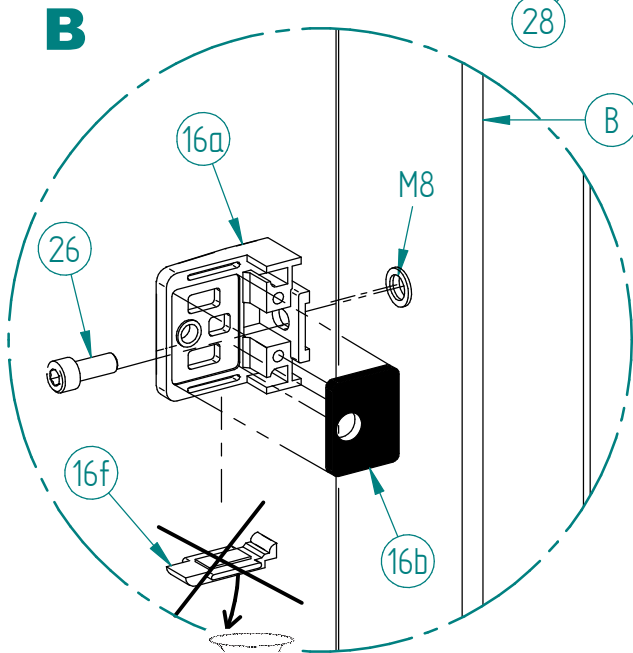
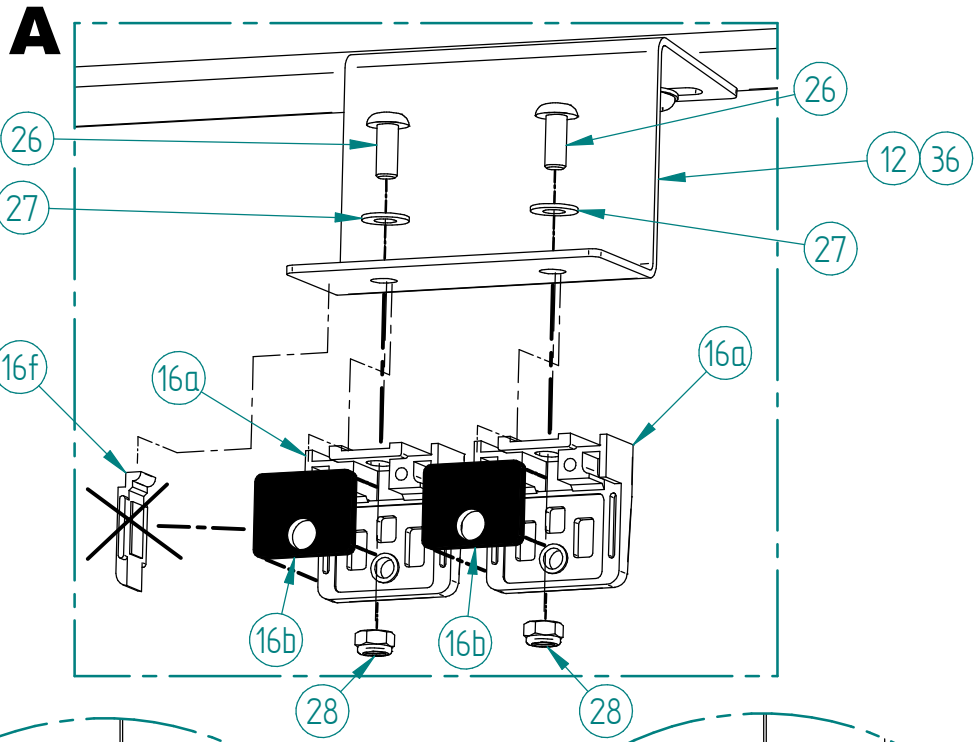

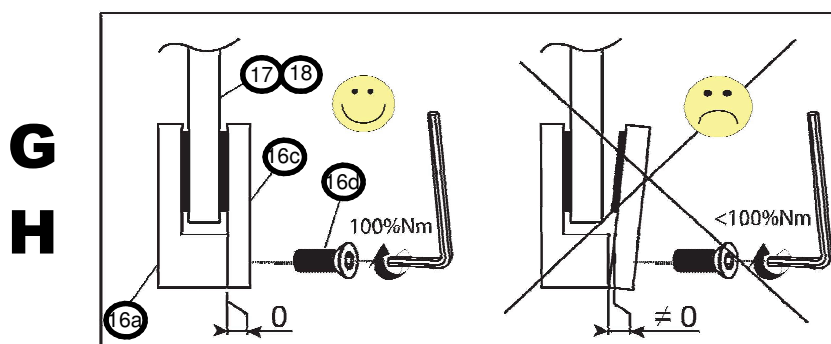
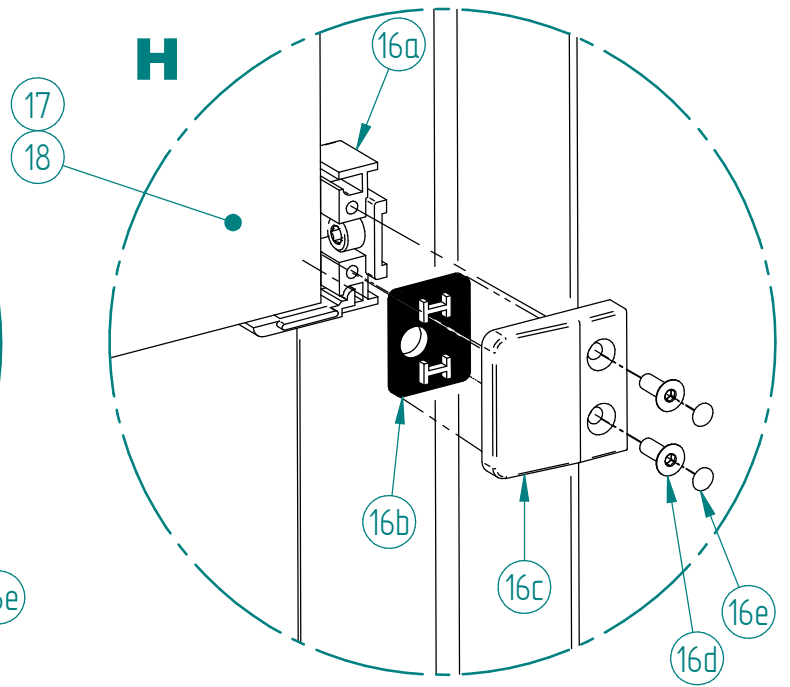
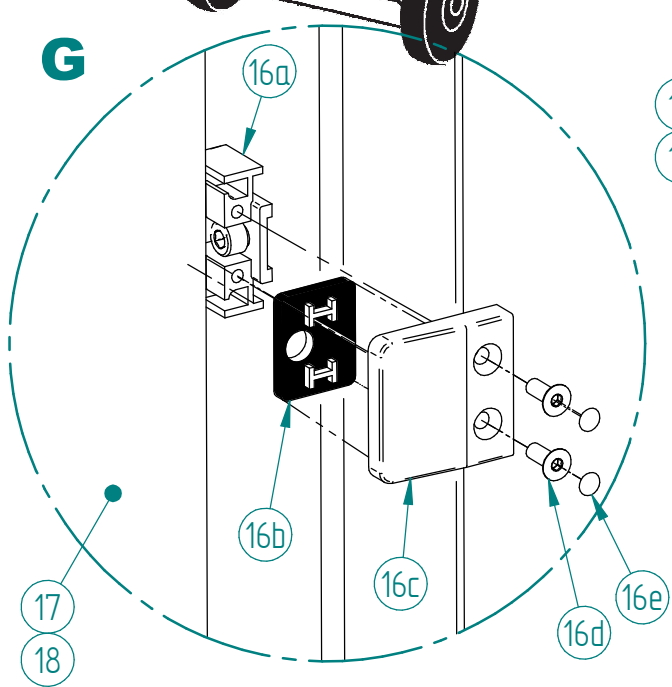
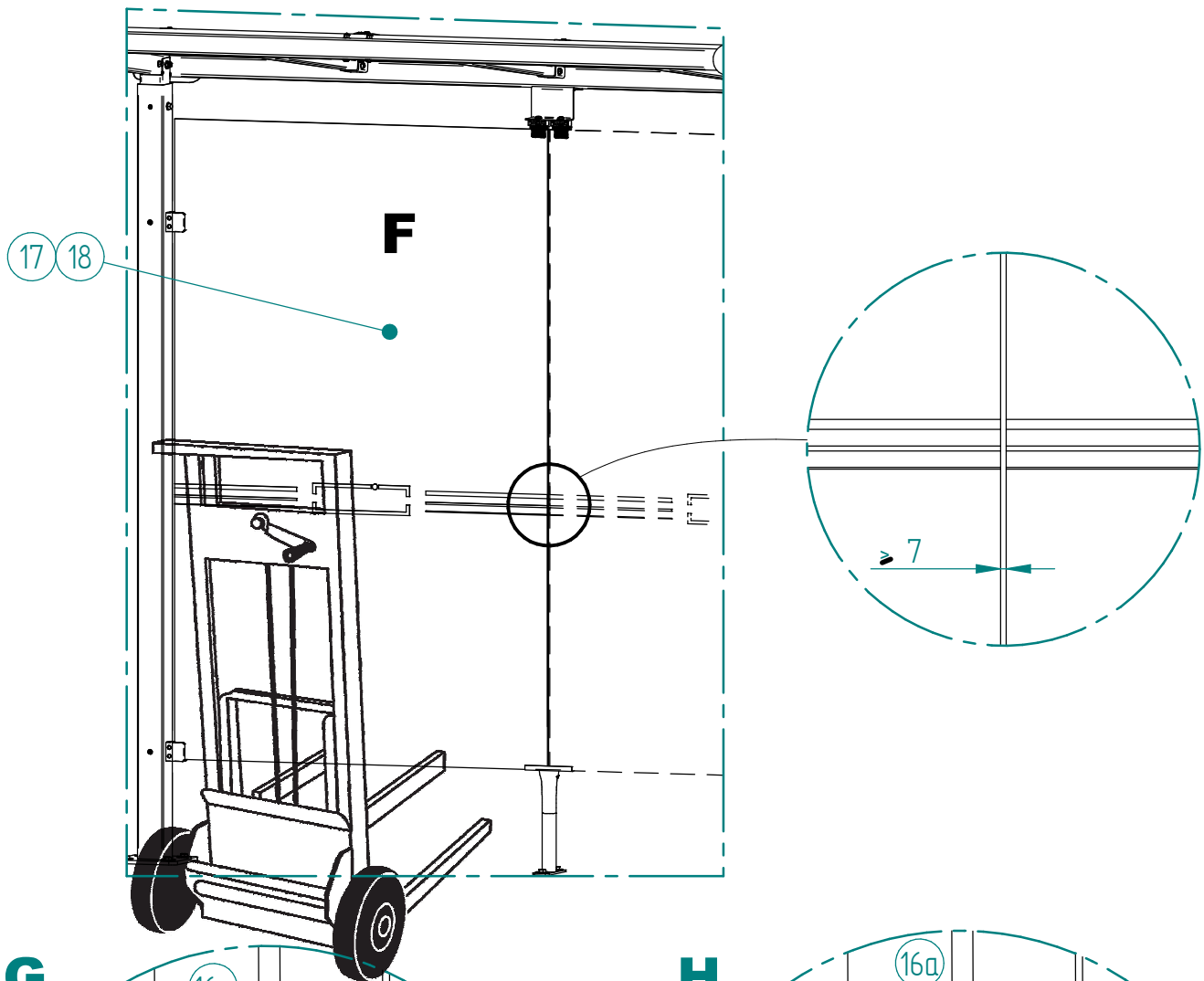

# VITRINE HORAIRE

## STATIONS BUS 80x80 ou ø76 - Réf. 505045

Réf. 505045

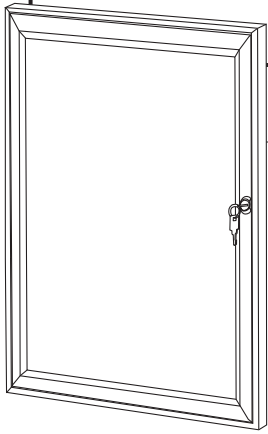

**Q** (x 1)

750 x 550

**Q4** (x 1)

SFI 529300-15

**Q1** (x 2)

ATE 529300.H

**Q2** (x 2)

ACC 10007

**Q3** (x 2)

BHC M6 x 16

ACC 22043

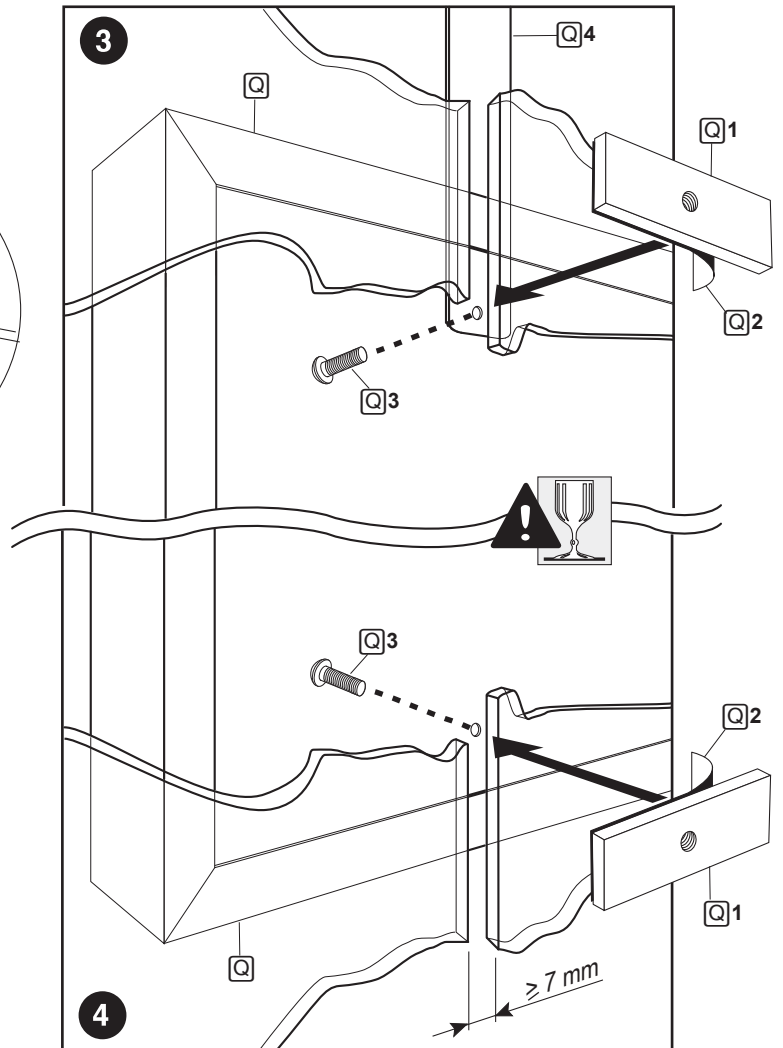
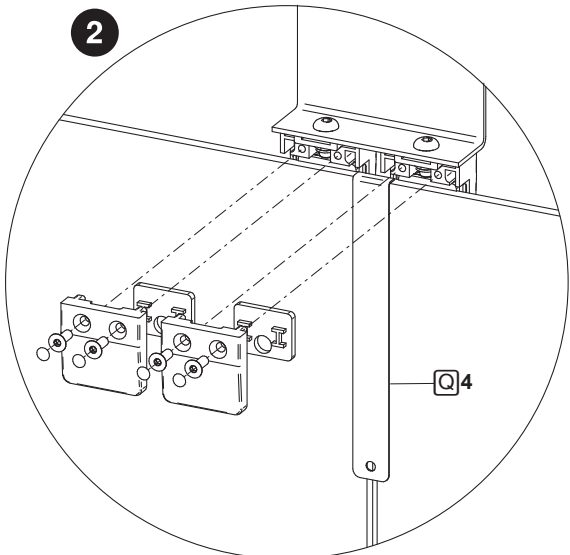
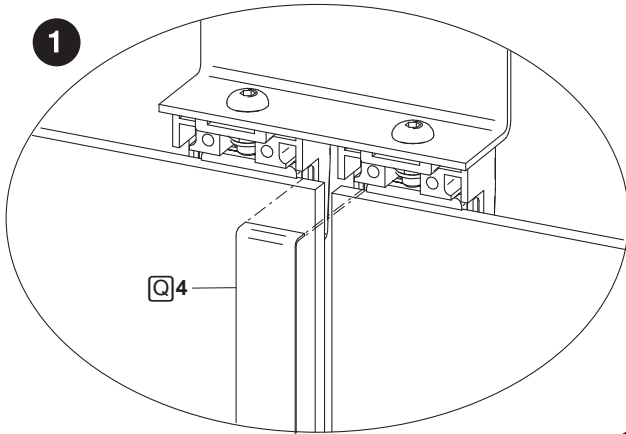
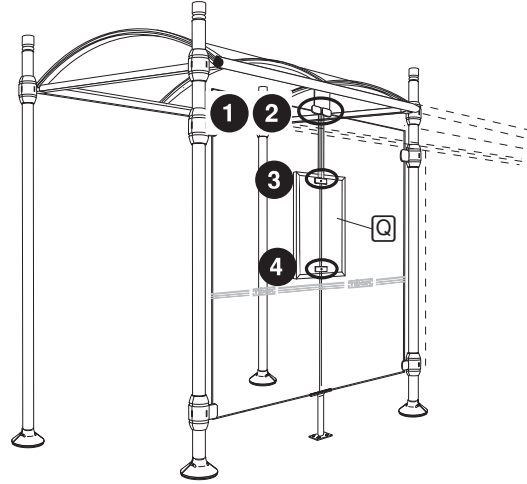
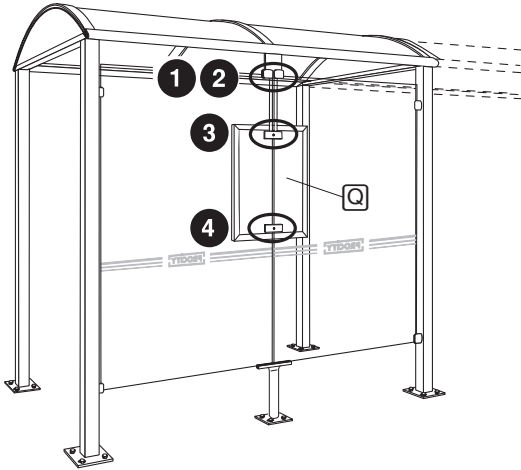



# Montage Poteaux & Traverses

## STATION-BUS MILAN

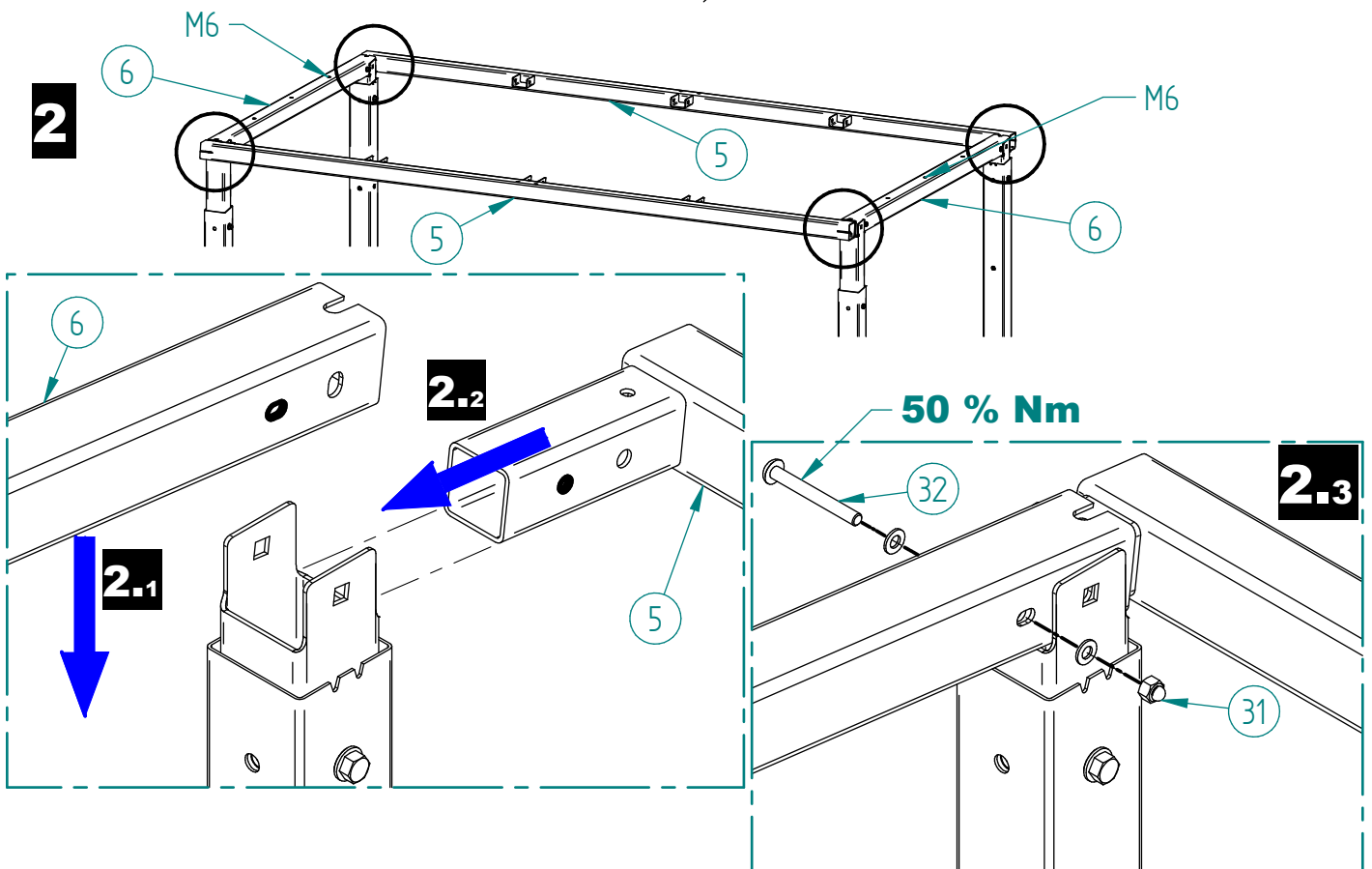
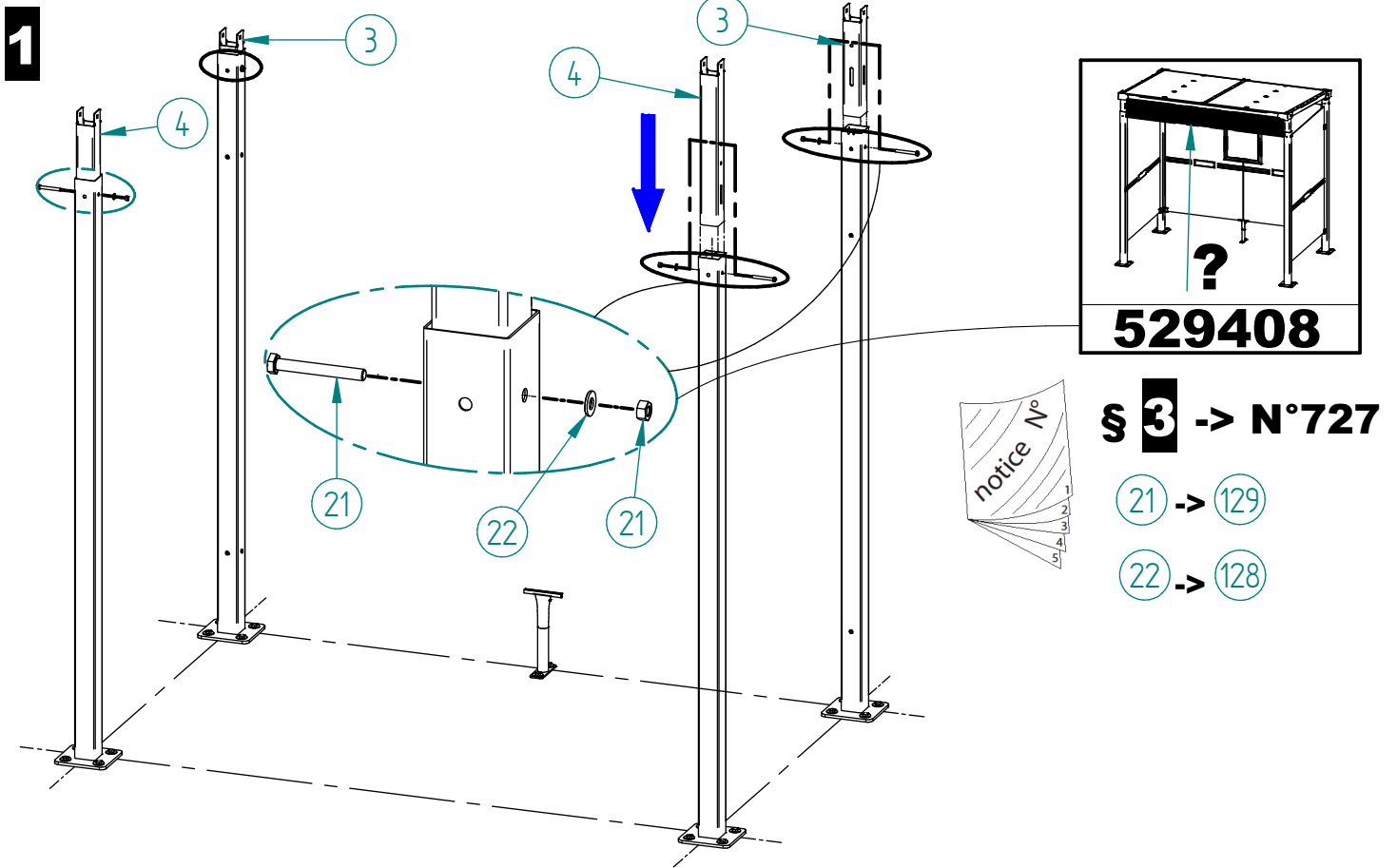



**5**

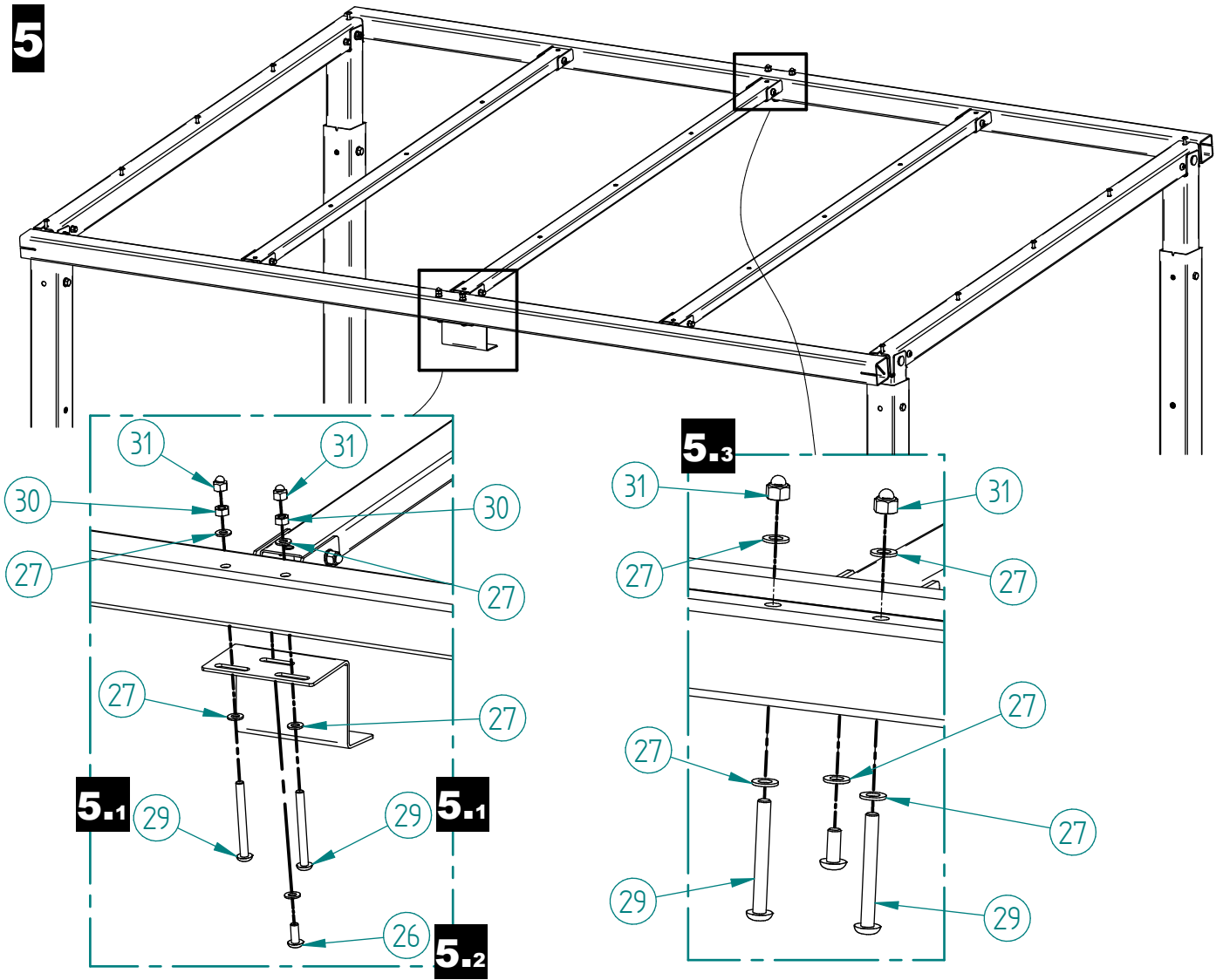

**6**

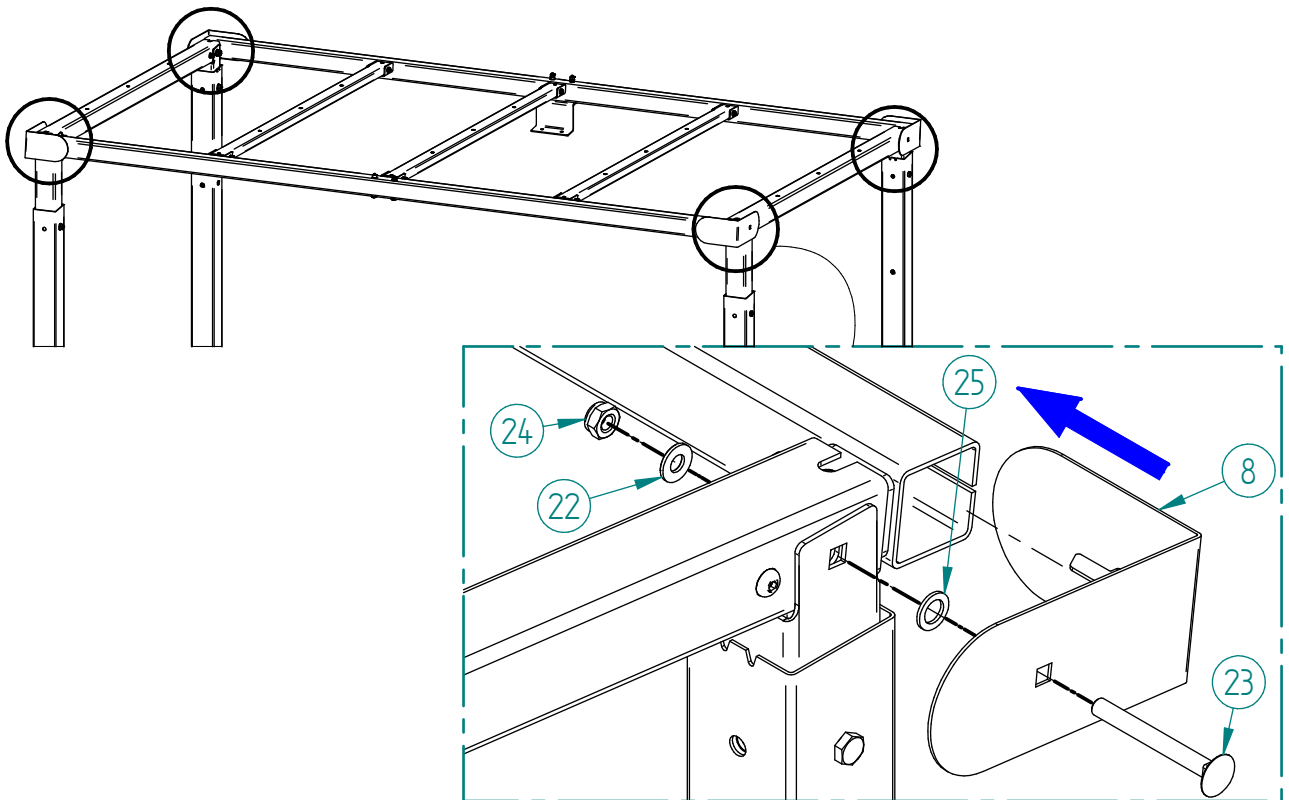

# Montage Toiture STATION-BUS MILAN

**1**

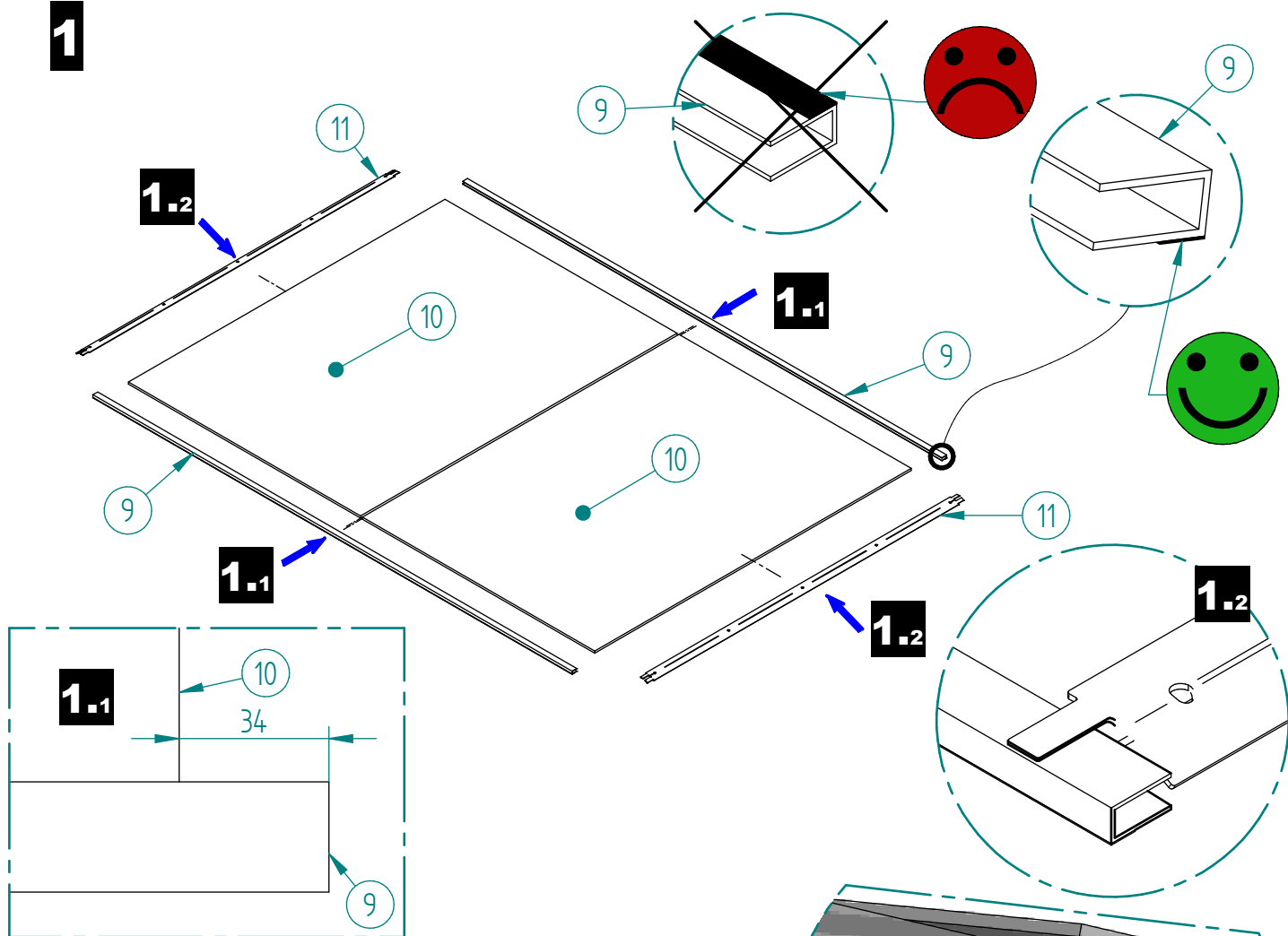

**2**

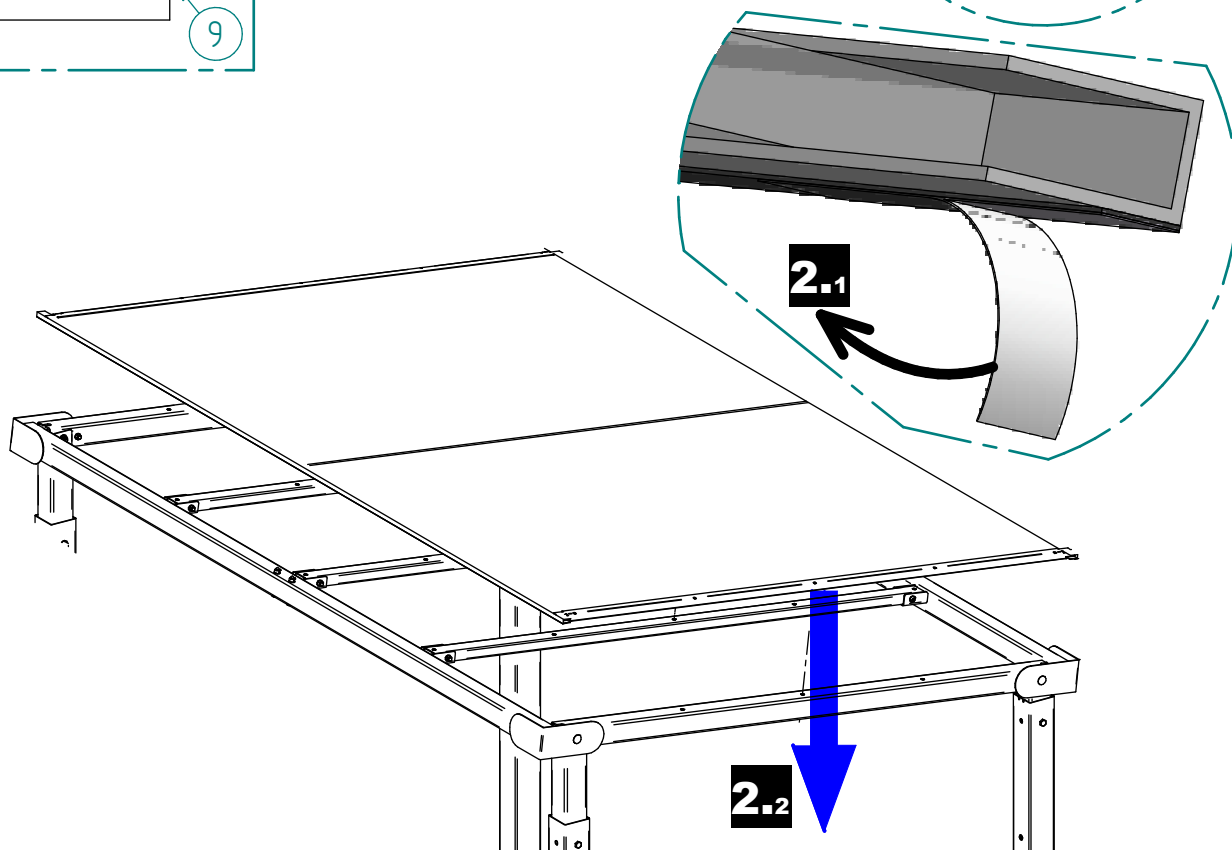

3

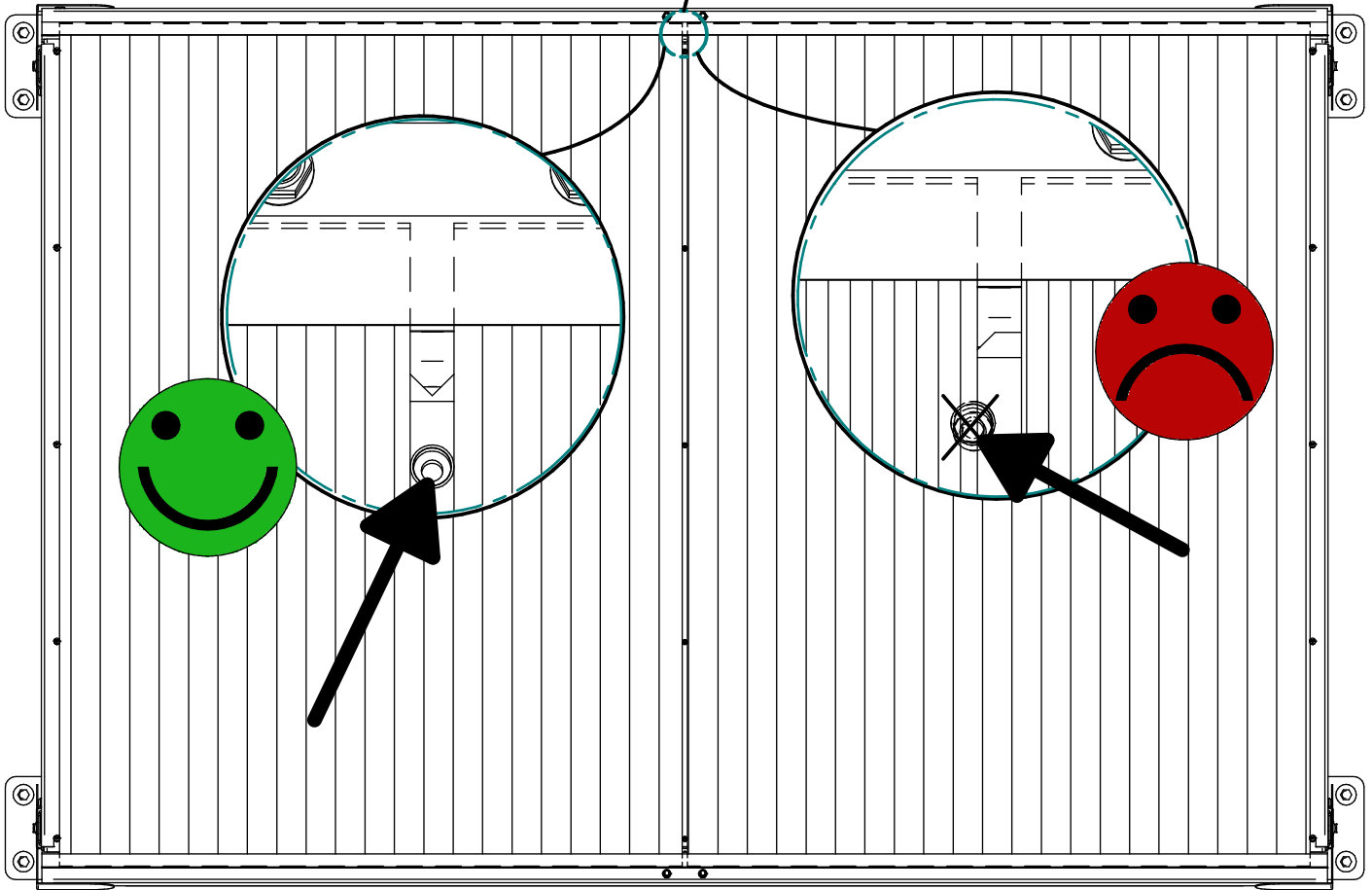
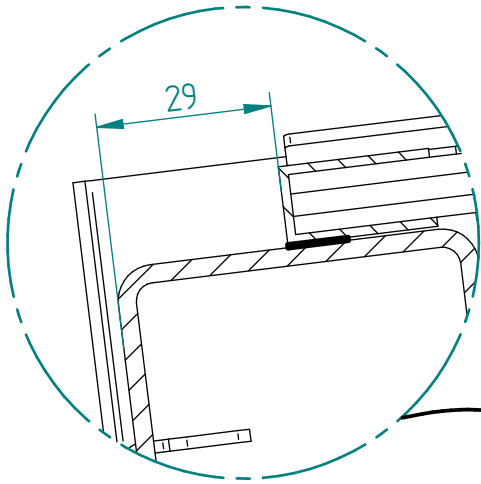

4

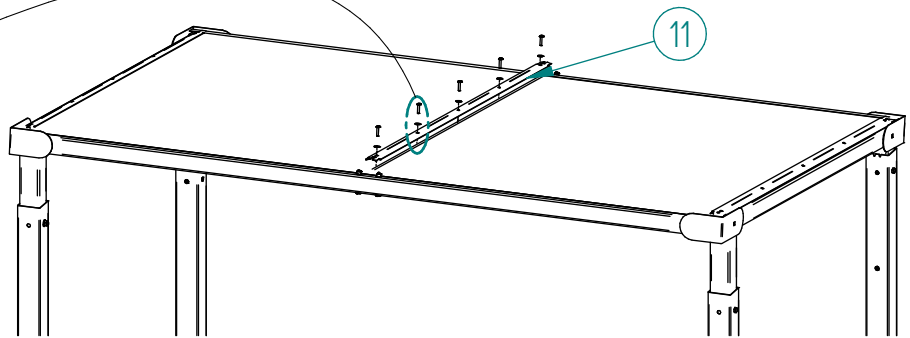
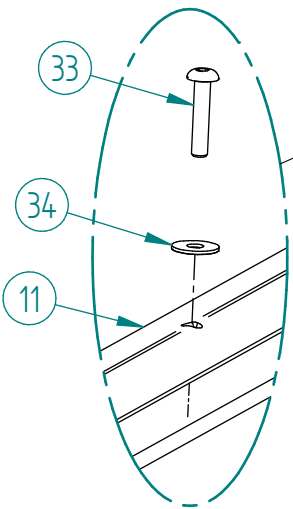

4

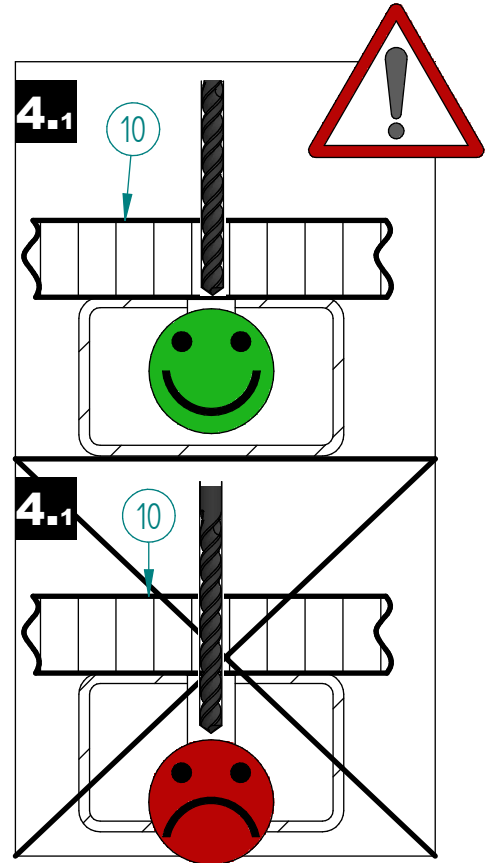
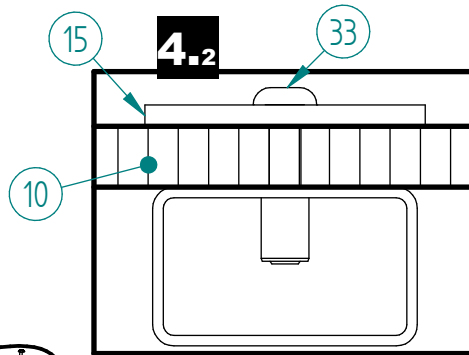
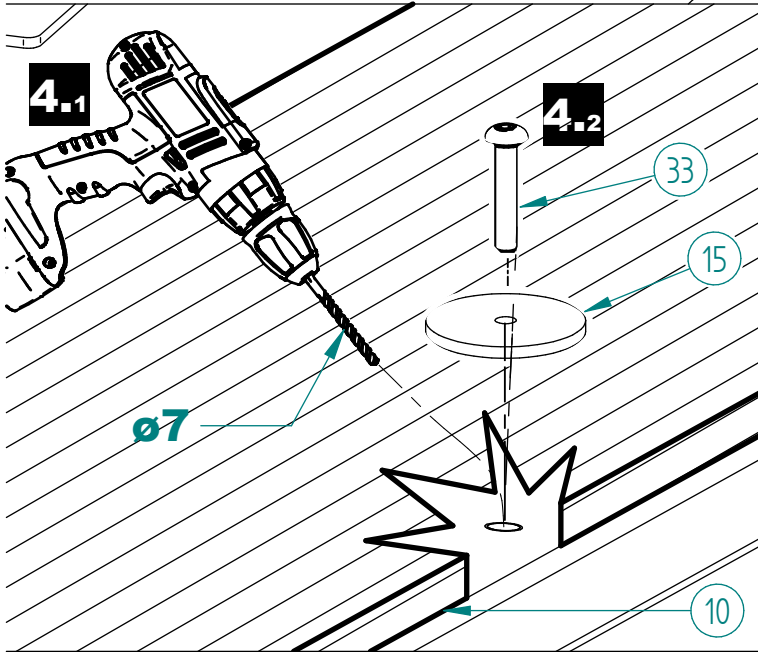
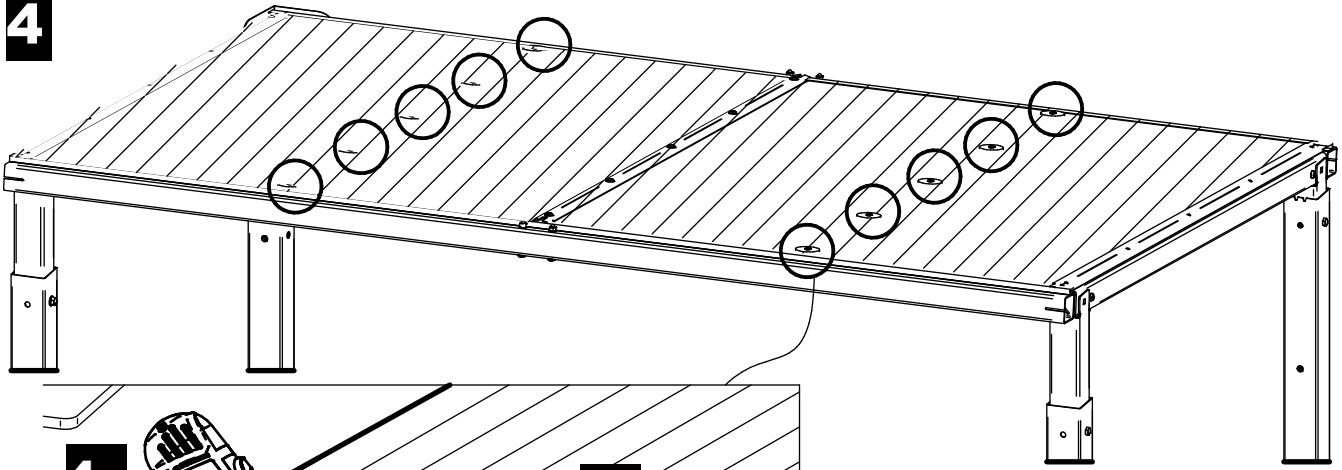

5

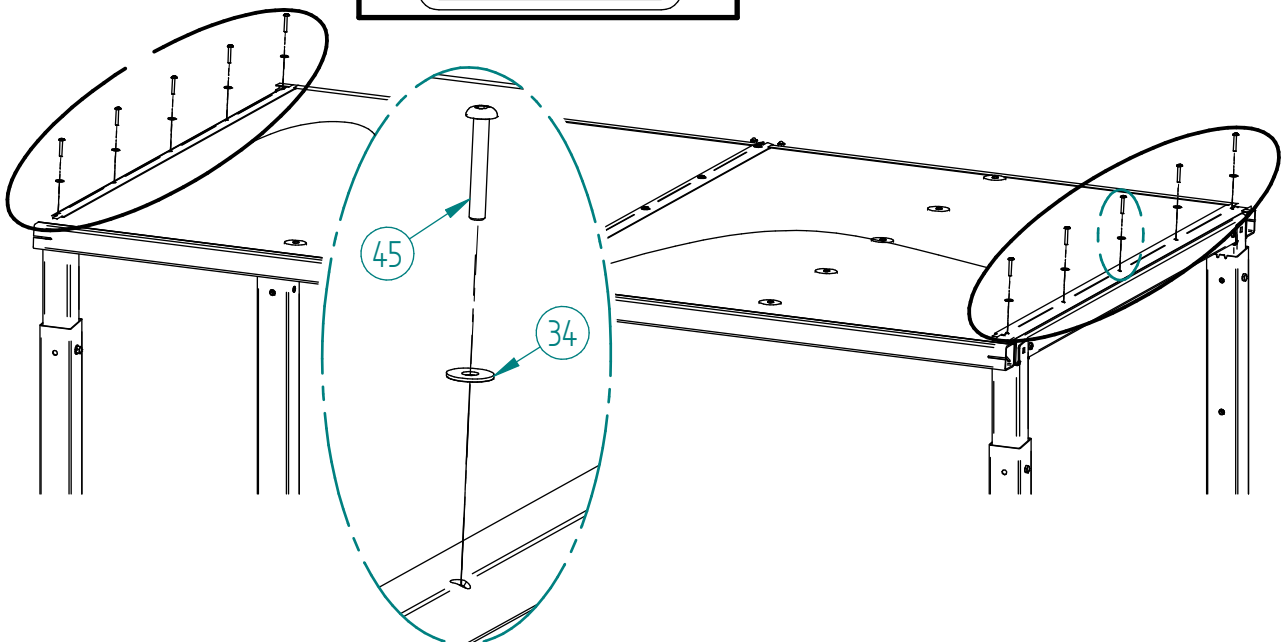

6

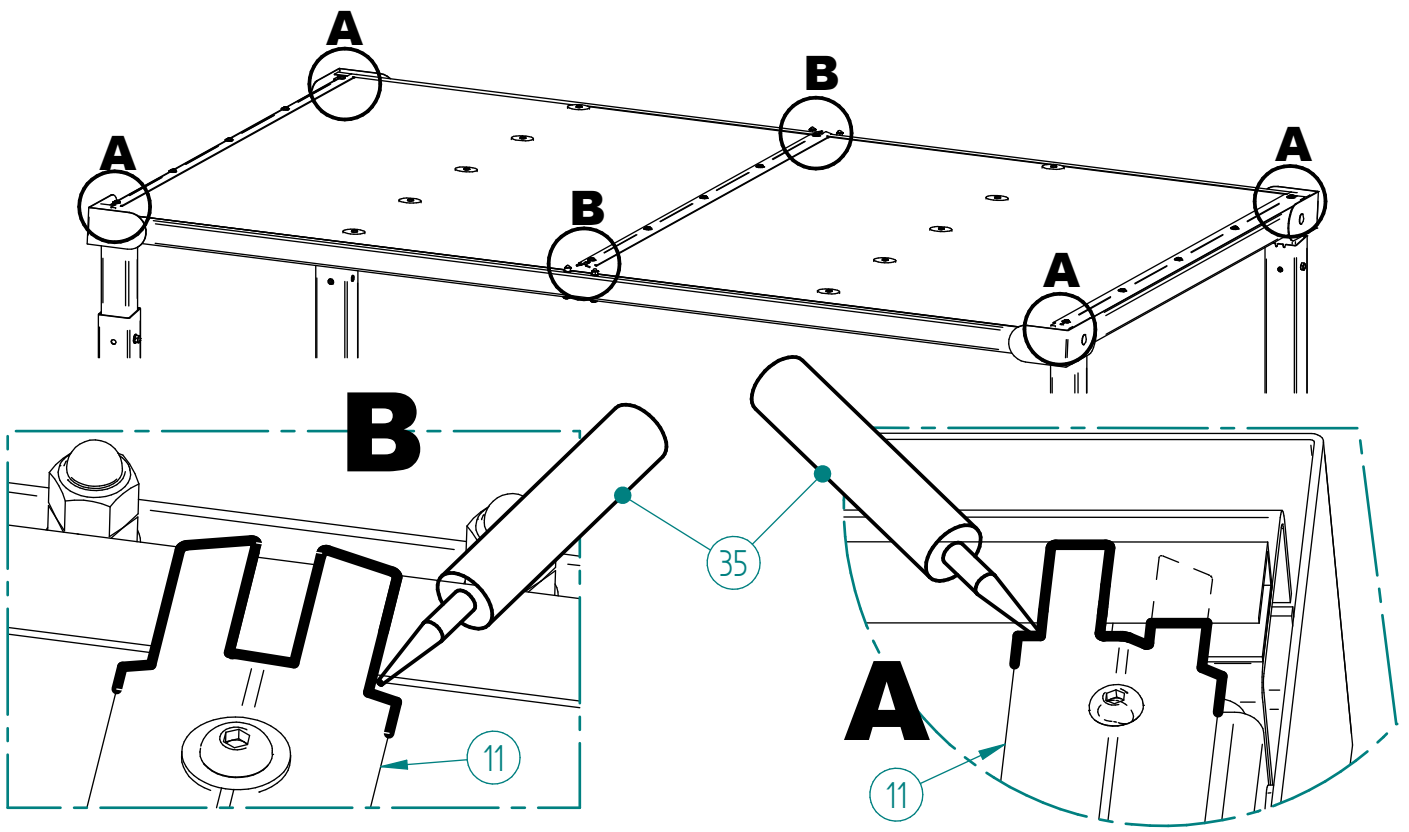

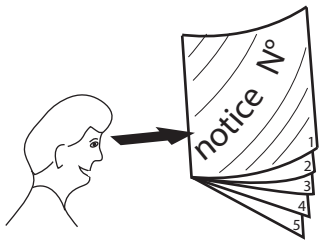

- 1) N°NOT805
- 2) N°E26P
- 3) N°153P



**Caisson d'information sur pied central avec vitre démontable  
Lumineux ou non lumineux pour Abri Milan**



508305



-----

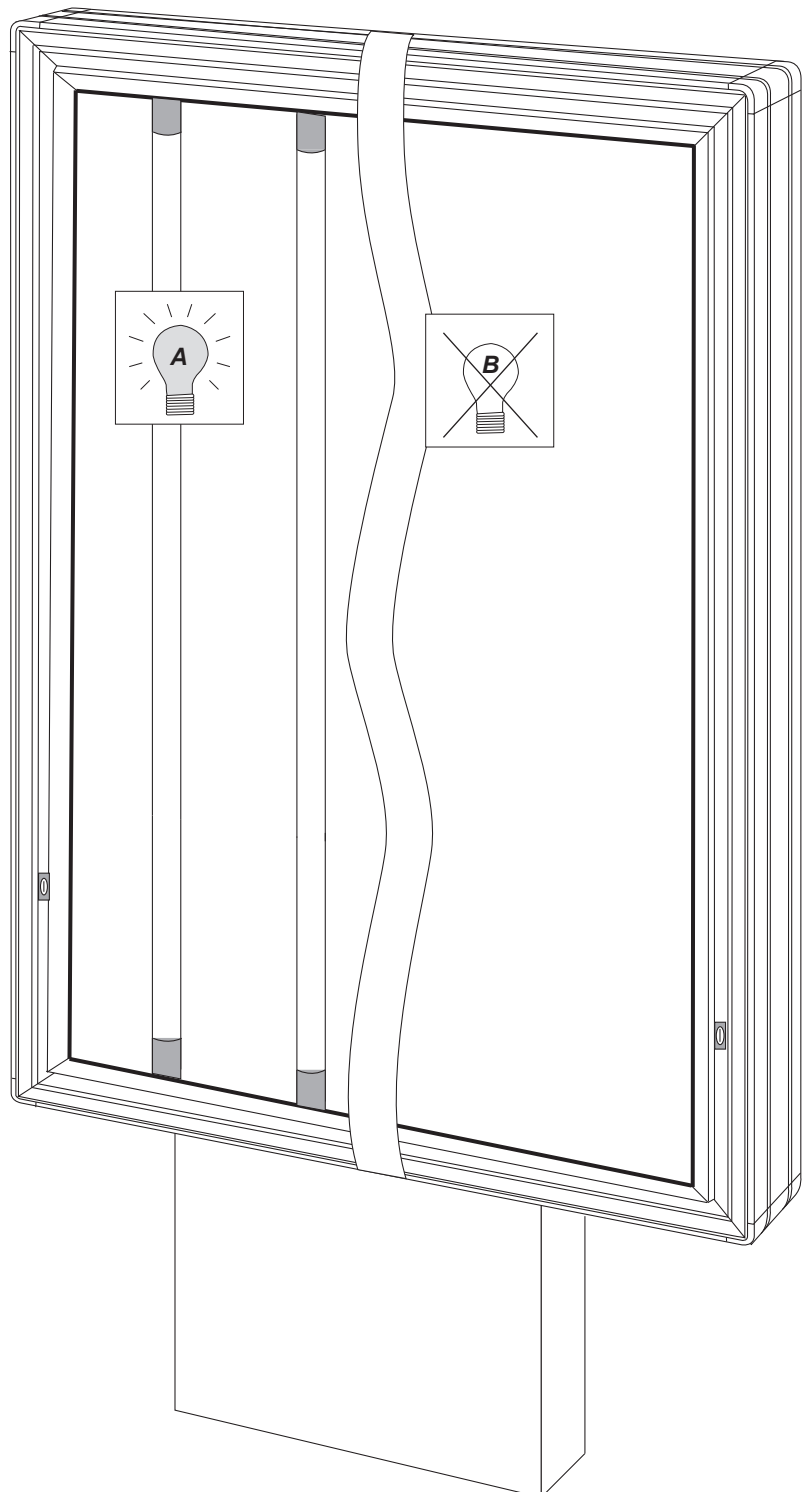



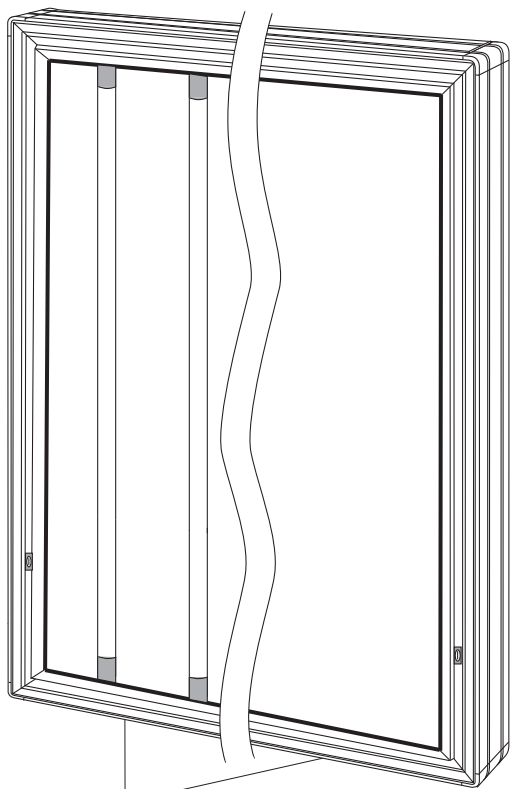

**N10** (x1)

508305A



**N11** (x1)

SFI 508305.A

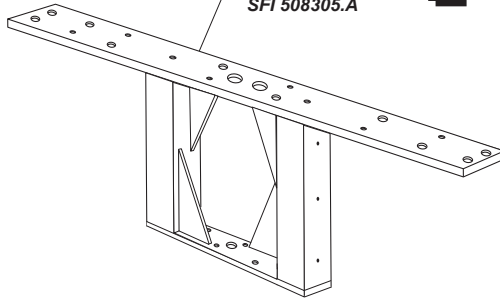

**N12** (x2)

ACC 508300.04

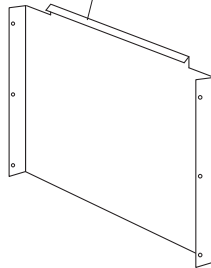

**N13** (x8)

60x40x3  
SFI 508300.18

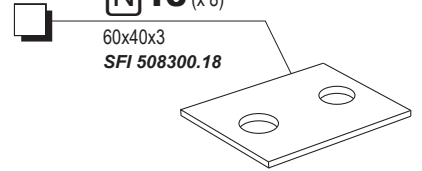

**N14** (x12)

HFr M10  
ACC 04987

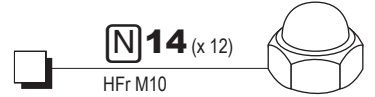

**N15** (x12)

M 10  
ACC 18146

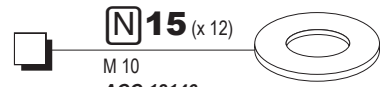

**N16** (x4)

HFr M8  
ACC 04986

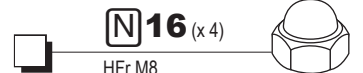

**N17** (x4)

M 8  
ACC 18145

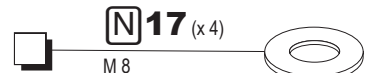

**N18** (x6)

3,5x13  
ACC 22301

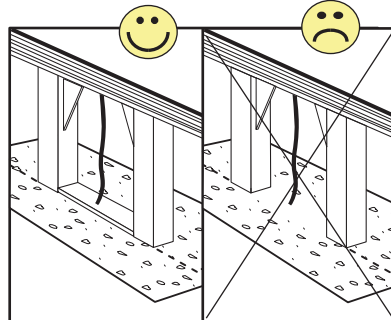
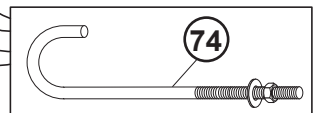
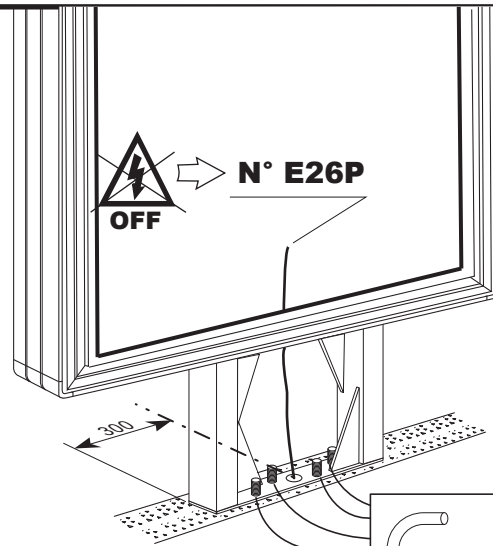
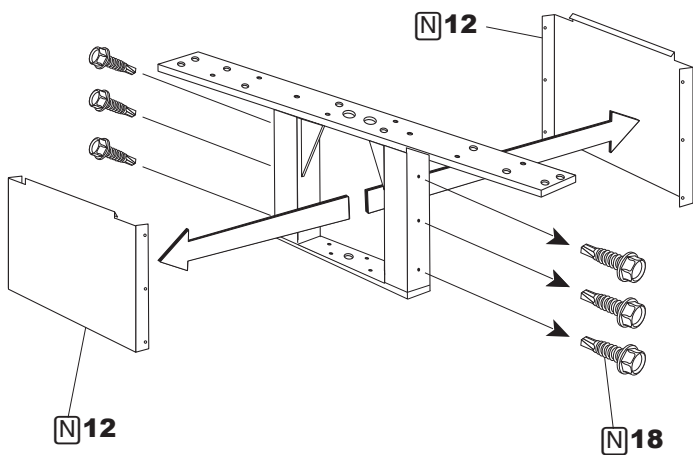
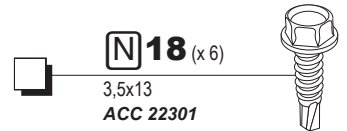

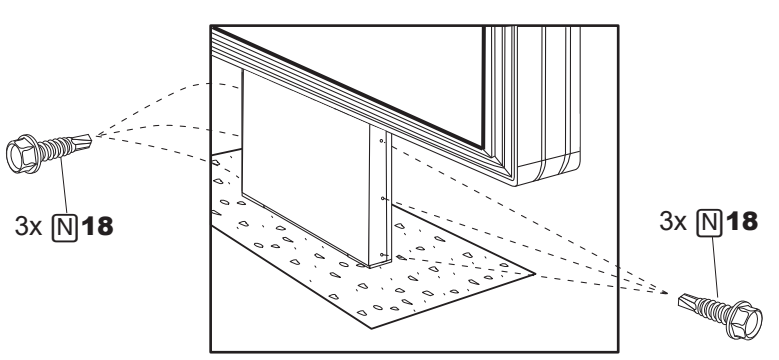
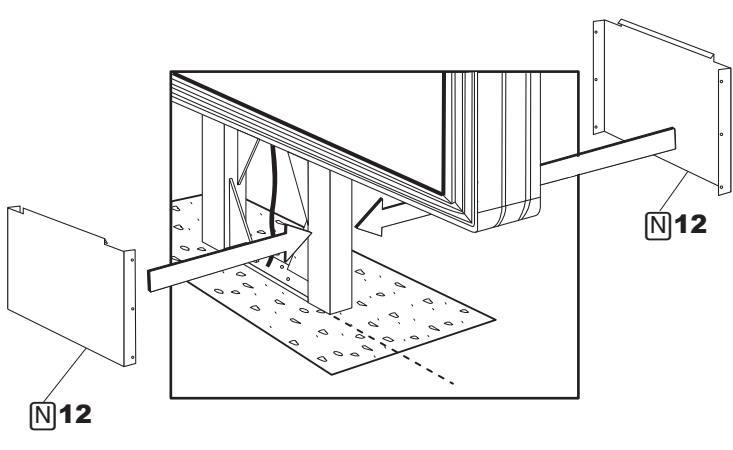
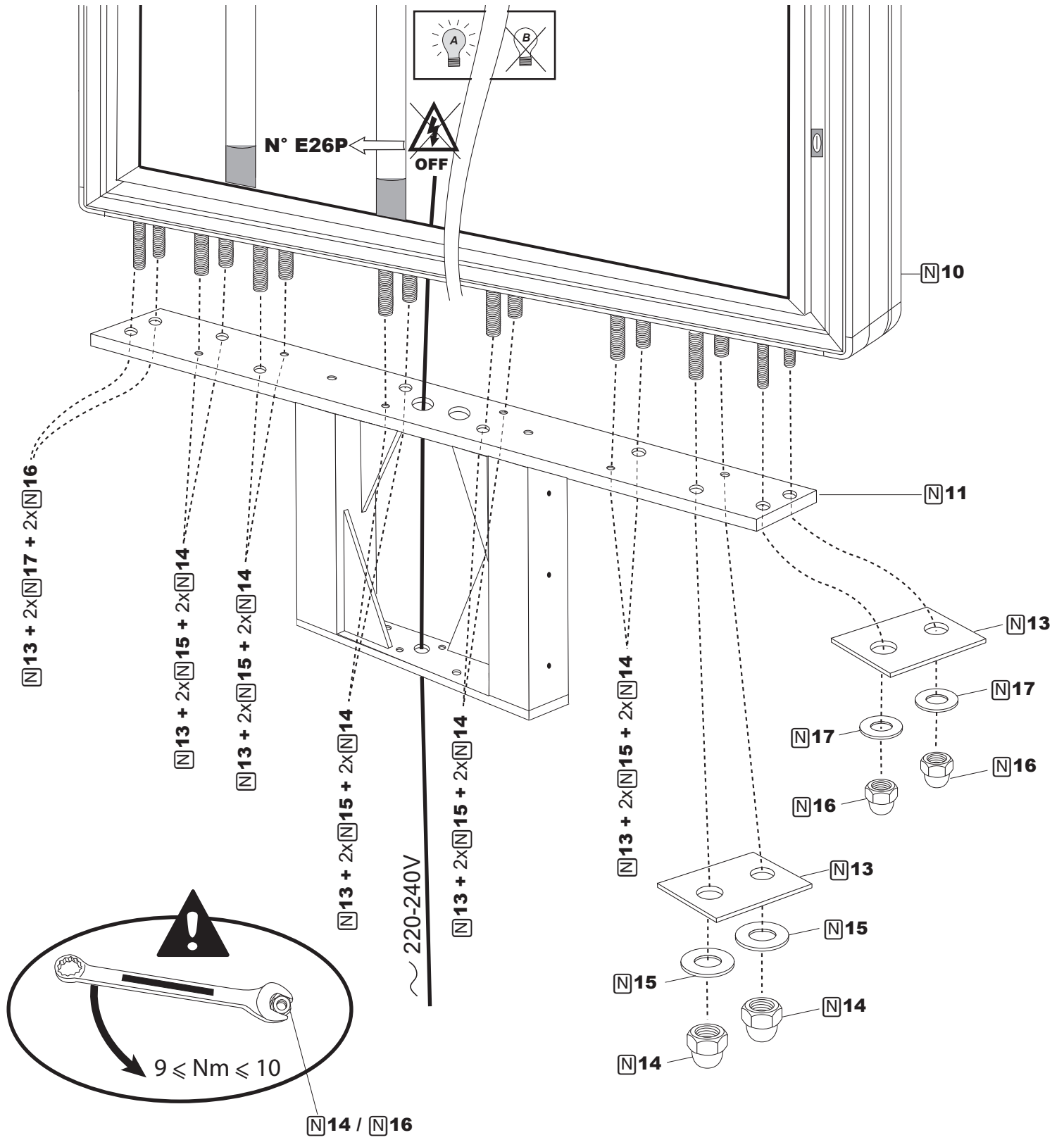

**OUT**

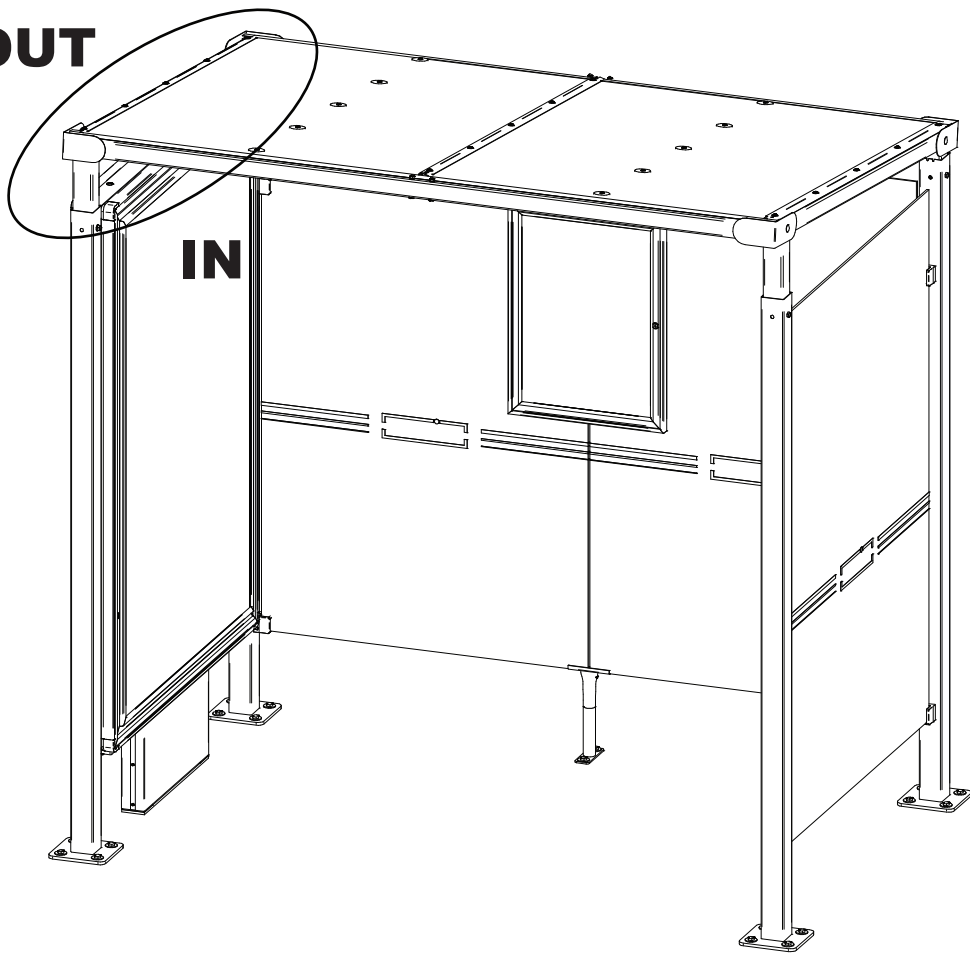

**OUT**

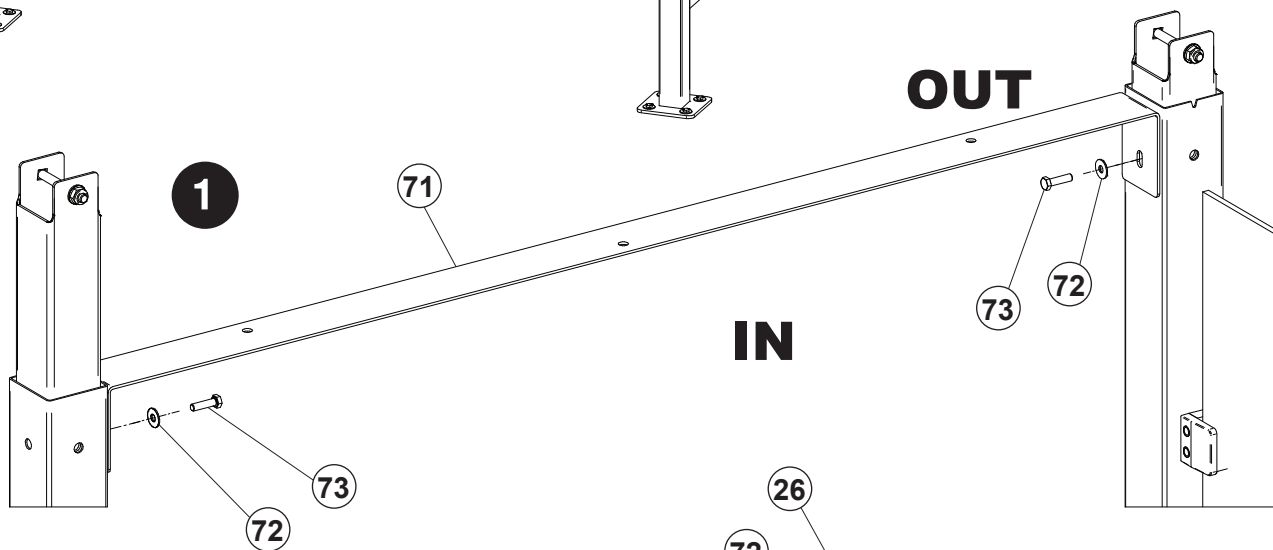

**IN**

**OUT**

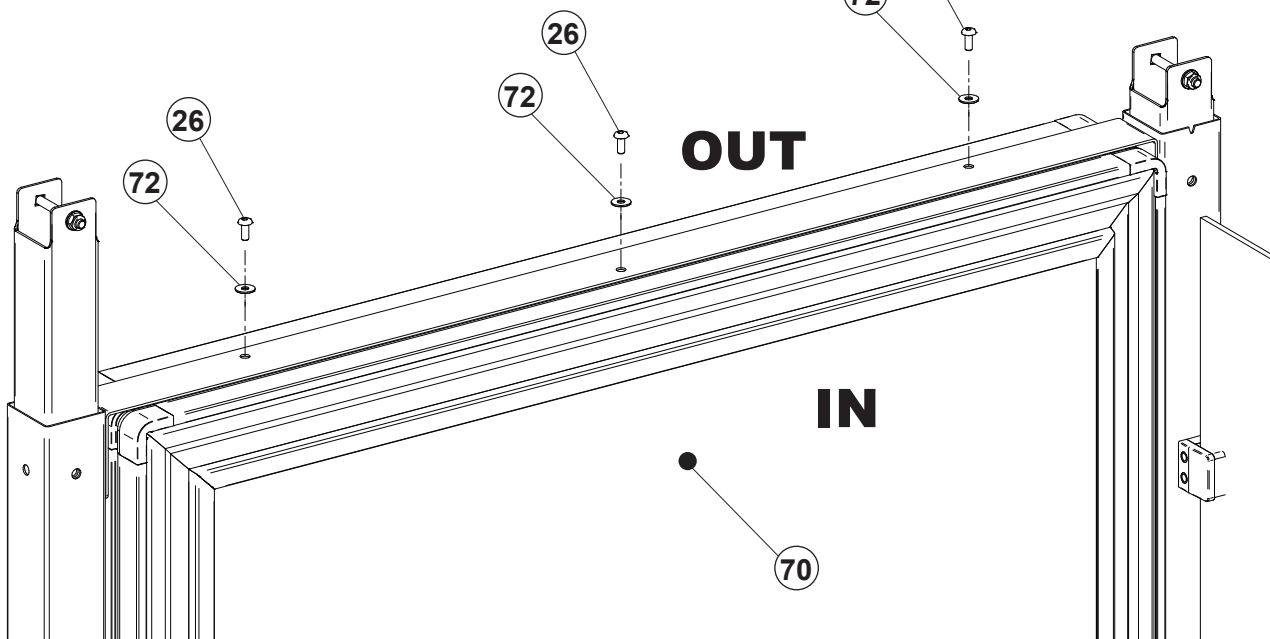

**IN**

# Positionnement et Fixation Poteaux: Abri Milan

Station bus 80x80 1 Caisson et 1 Bardage Latéral à Gauche (ou à Droite) (2 modules)

