



# PITTMAN HUDSON BIKE SHELTER

**pittman**<sup>®</sup>

## OVERVIEW

The Hudson Bike Shelter is a robust, weather-resistant bicycle storage solution designed to meet the demands of modern urban environments.

Built for long-term durability, this surface-mounted shelter features a spacious layout measuring 4100 mm in length, 2214 mm in depth, and 2424 mm in height. Ideal for safely accommodating multiple bicycles without occupying excessive space.

Its 3mm thick polycarbonate (PC) roof provides superior protection against UV rays and harsh weather, ensuring year-round usability.

The shelter's steel frame is hot dip galvanized and powder coated, delivering exceptional resistance to corrosion and reducing the need for maintenance.

## FEATURES

- **Hot dip galvanized and powder coated** - delivering exceptional resistance to corrosion and reducing the need for maintenance.
- **High-strength roof material** - Provides superior protection against UV rays, rain, and snow for year-round use
- **Spacious design** - offers ample storage capacity for multiple bicycles while maintaining a compact site footprint
- **Sub-surface mounting** - enables stable, tamper-resistant installation on concrete or paved areas.

# TECHNICAL DATA

SPECIFICATIONS	DETAILS	
Product Code	SKU: 797882	SKU: 797873
Color	Black	Grey
Front Height	2424.75 mm	
Rear Height	2230 mm	
Lenght	4100 mm	
Depth	2214.71 mm	
Finish	Powder Coated	
Roof Material	Ploycarbonate	
Frame Material	Hop Dip Galvanised Steel	

## DRAWINGS

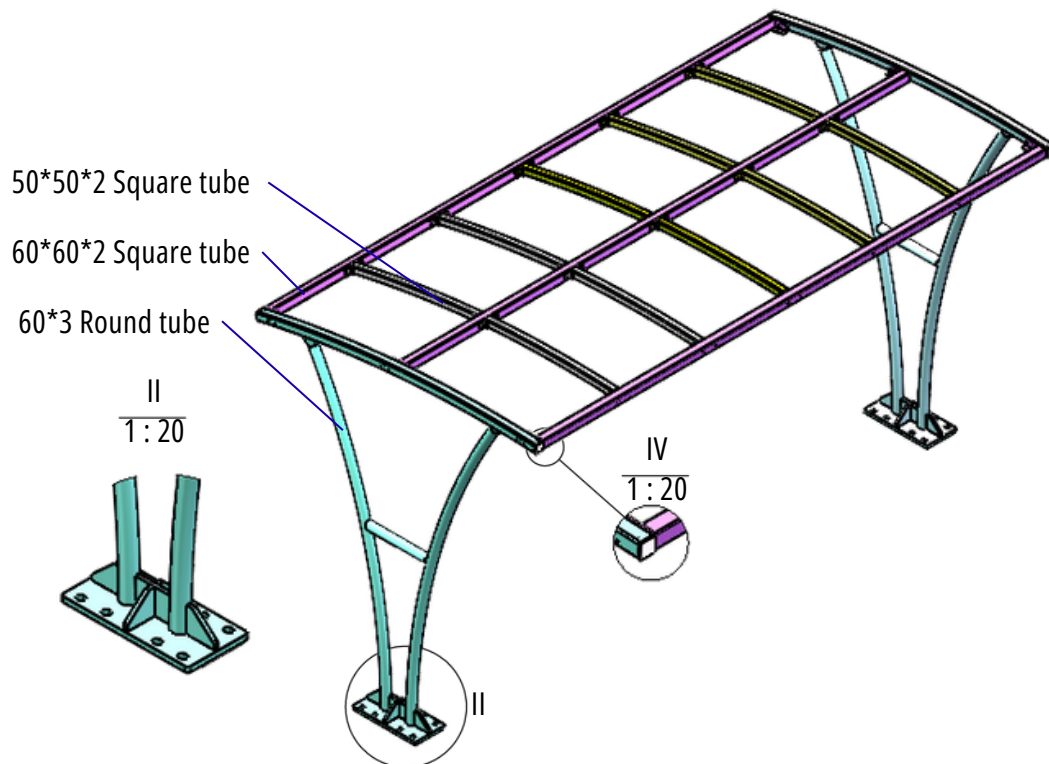

# DRAWINGS

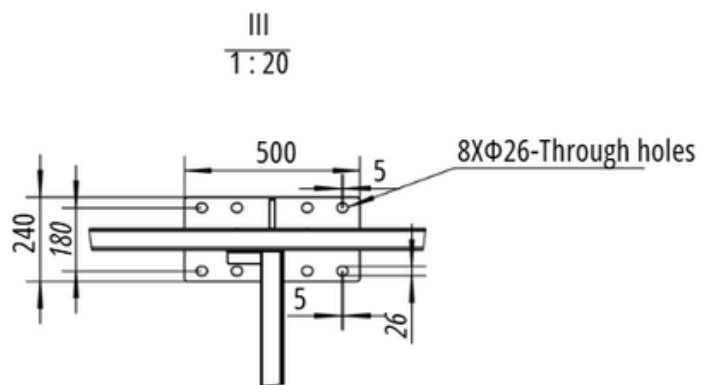
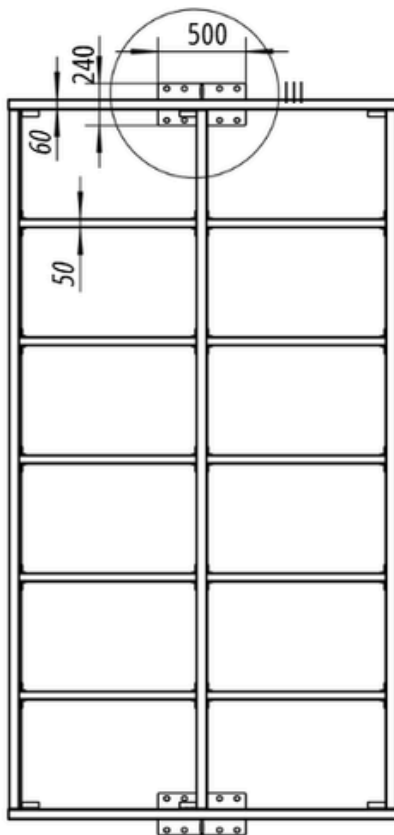
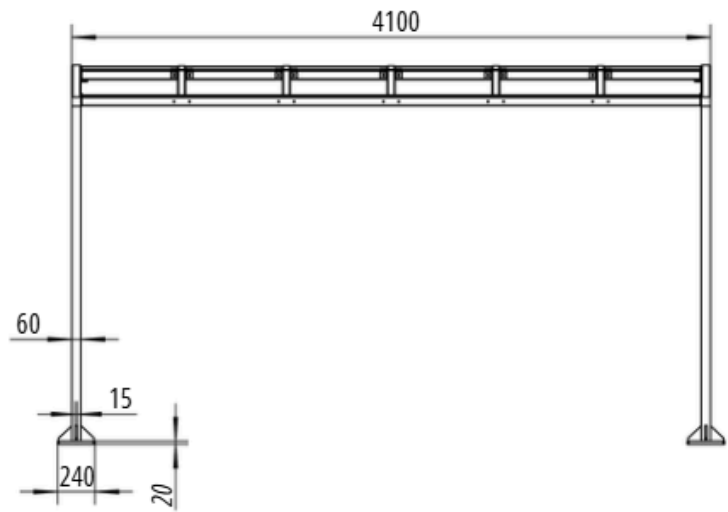
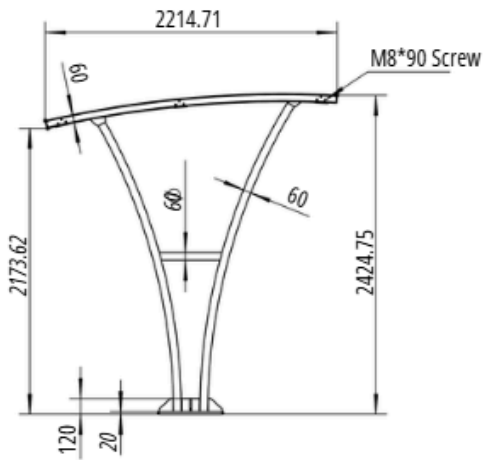

# DRAWINGS (EXTENDED VERSION)

