



BARRIER SYSTEM

pittman[®]

OVERVIEW

The Barrier System is designed to provide durable, long-lasting protection in environments where vehicle and pedestrian segregation is required. Combining corrugated steel beams, RSJ posts, and safety accessories, it offers a robust solution for protecting people, equipment, and infrastructure in industrial and commercial settings. All components are manufactured under quality control systems compliant with BS EN ISO 9001 and galvanised in accordance with BS EN ISO 1461.

Its robust construction resists wear and tear, providing peace of mind in even the busiest worksites or public spaces. The high-quality finish ensures protection from the elements, delivering a barrier system that is both tough and low-maintenance. Designed to integrate seamlessly with compatible components, the system offers a versatile solution for creating tailored layouts to meet specific safety requirements.

PRODUCT FEATURES

- Robust construction ensures the beam resists wear and tear, providing peace of mind on even the busiest worksites or public spaces
- Choice of finish, Galvanised or Powder Coated Yellow (RAL 1007)
- Numerous ends to make safety seamless
- Suitable for warehouses, factories, car parks and logistic depots



TECHNICAL DATA (3.2m Effective Straight Beam)



SPECIFICATIONS	DETAILS
Product Code	SKU: 755698
Material	Hot-dip Galvanised Steel
Finish (Optional)	Galvanised or Powder Coated Yellow (RAL 1007)
Overall Length	3510mm
Effective Length	3200 mm
Height	310mm
Thickness	3 mm
Weight	40 kg
Base Plate	300 x 250mm
Fixings	(8) M16 x 35mm Post bolt for overlapping beams /connect fishtail to end of beam

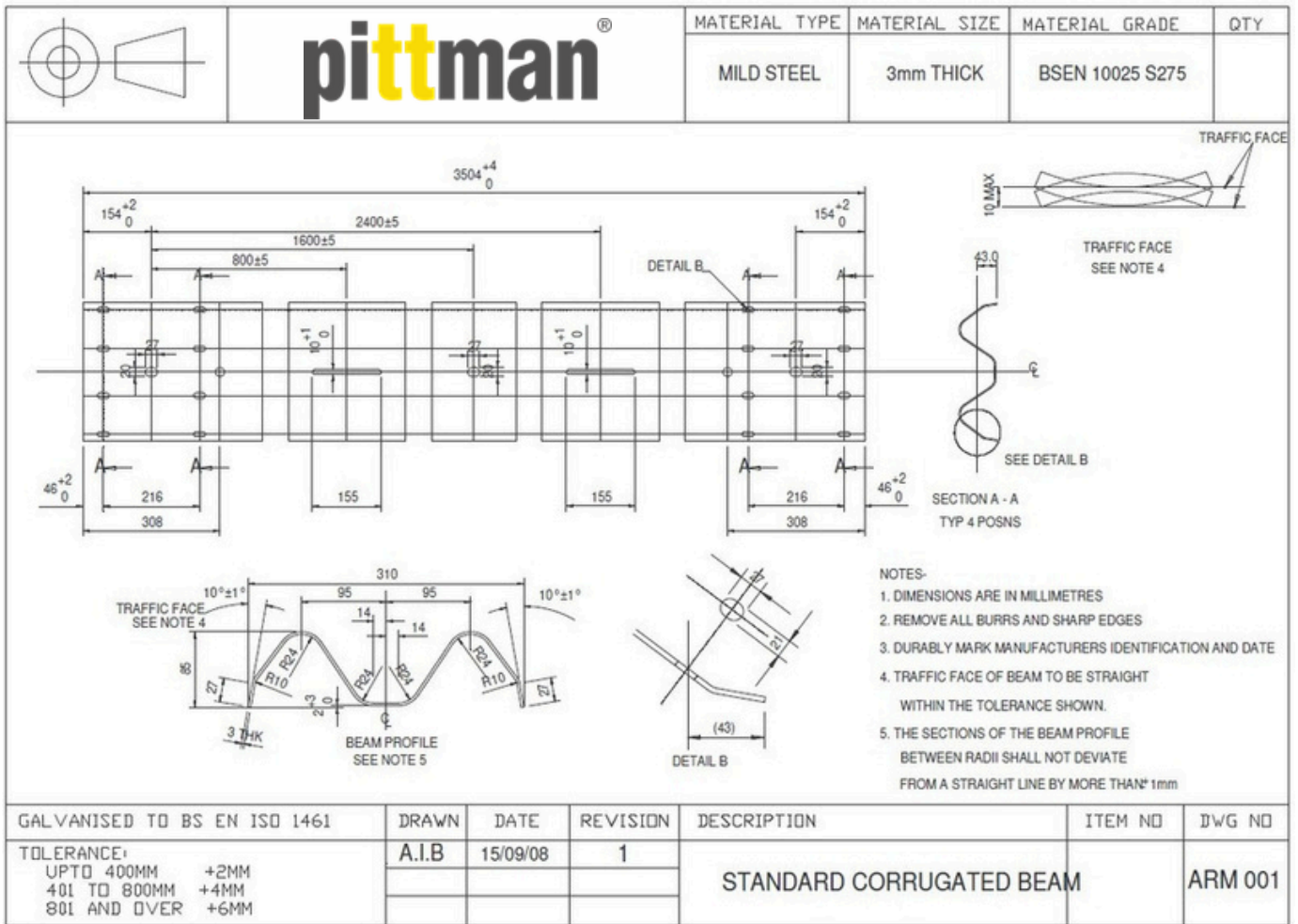

Bolt Down RSJ Post - 760mm



SPECIFICATIONS	DETAILS
Product Code	SKU: 755699
Material	Galvanised Steel
Height	760 mm
Width	76 mm
Depth	127 mm
Thickness	13 mm
Weight	16.25 kg
Base Plate	300 x 250mm
Fixings	M16 x 125mm anchor bolts, M16 x 50mm beam to post bolt

2 x 760mm RSJ Posts

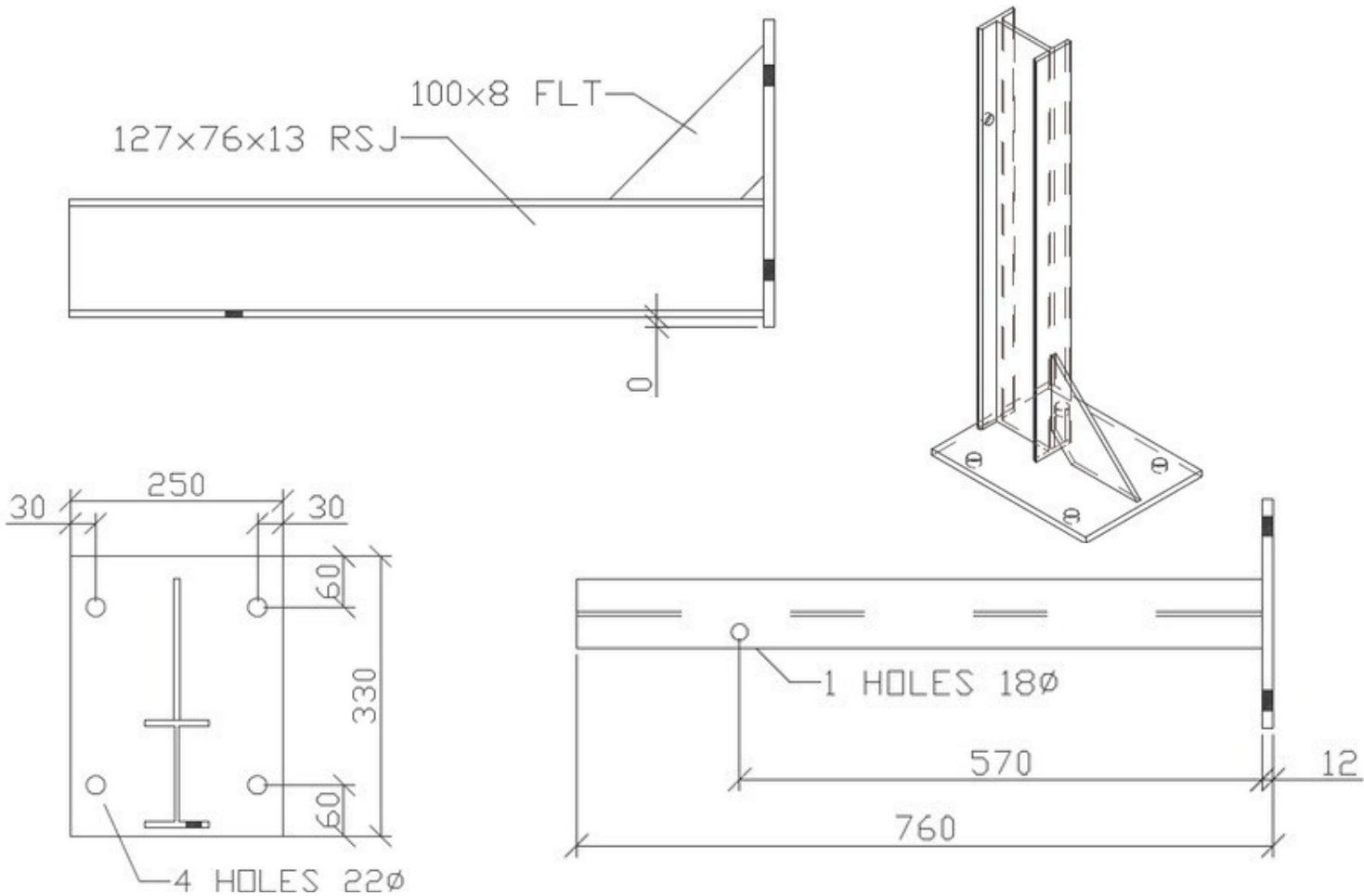

Fishtail End



SPECIFICATIONS	DETAILS
Product Code	SKU: 755701
Material	Galvanised Steel
Finish (Optional)	Galvanised or Powder Coated Yellow (RAL 1007)
Height	250 mm
Width	405 mm
Length	700 mm
Colour	Yellow (RAL 1007)
Weight	16.25 kg
Use	Bolts onto beam end to protect against sharp edges
Fixings	8 x M16 x 35mm lap bolts

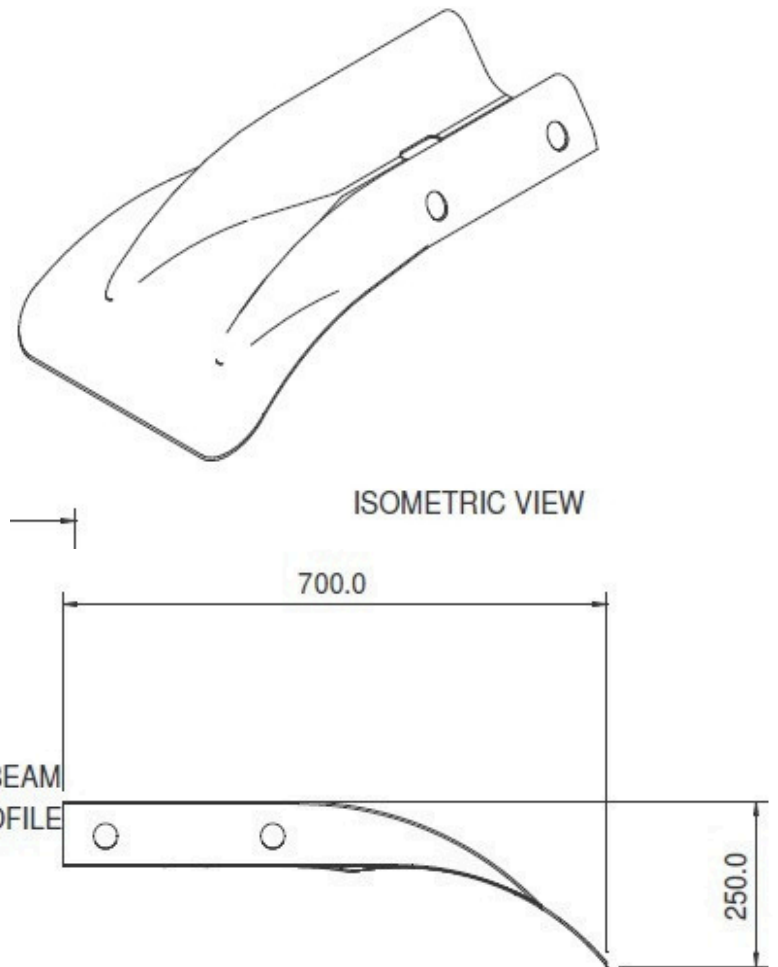
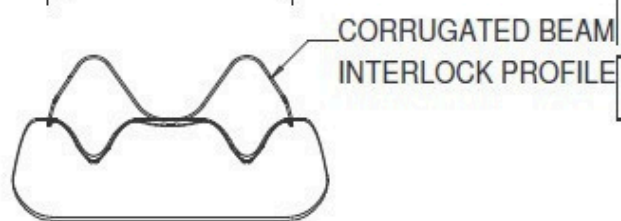
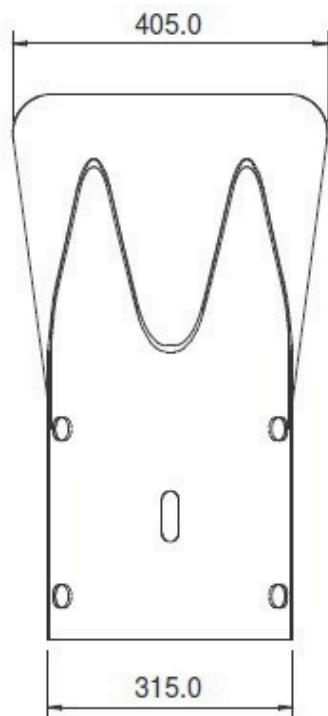

Pedestrian End



SPECIFICATIONS	DETAILS
Product Code	SKU: 755703
Material	Hot-dip Galvanised Steel
Height	315 mm
Width	438 mm
Depth	85 mm
Use	Rounded cover for beam ends
Fixings	8 x M16x50mm lap bolts

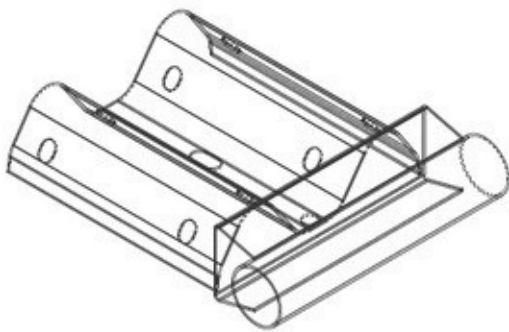

ISOMETRIC VIEW

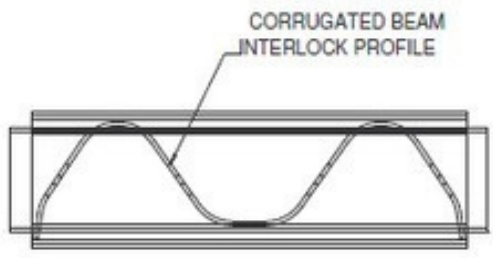
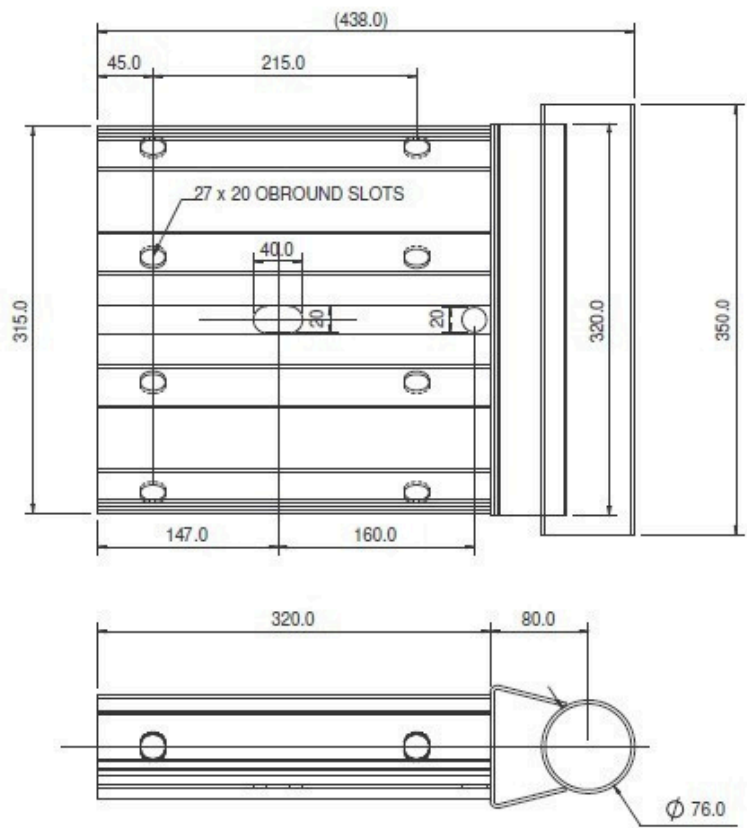

90° Internal Corner



SPECIFICATIONS	DETAILS
Product Code	SKU: 755705
Material	Galvanised Steel
Height	315 mm
Width	450 mm
Length	450 mm
Fixing	8 x M16x35mm Lap Bolt

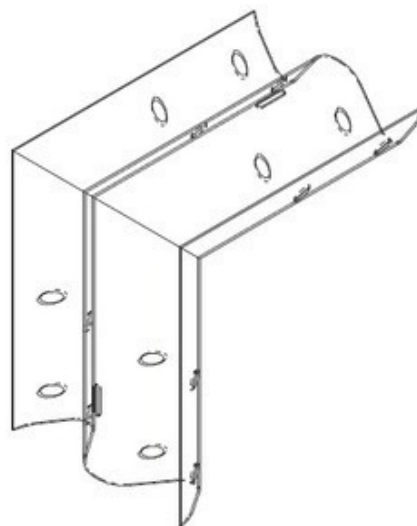
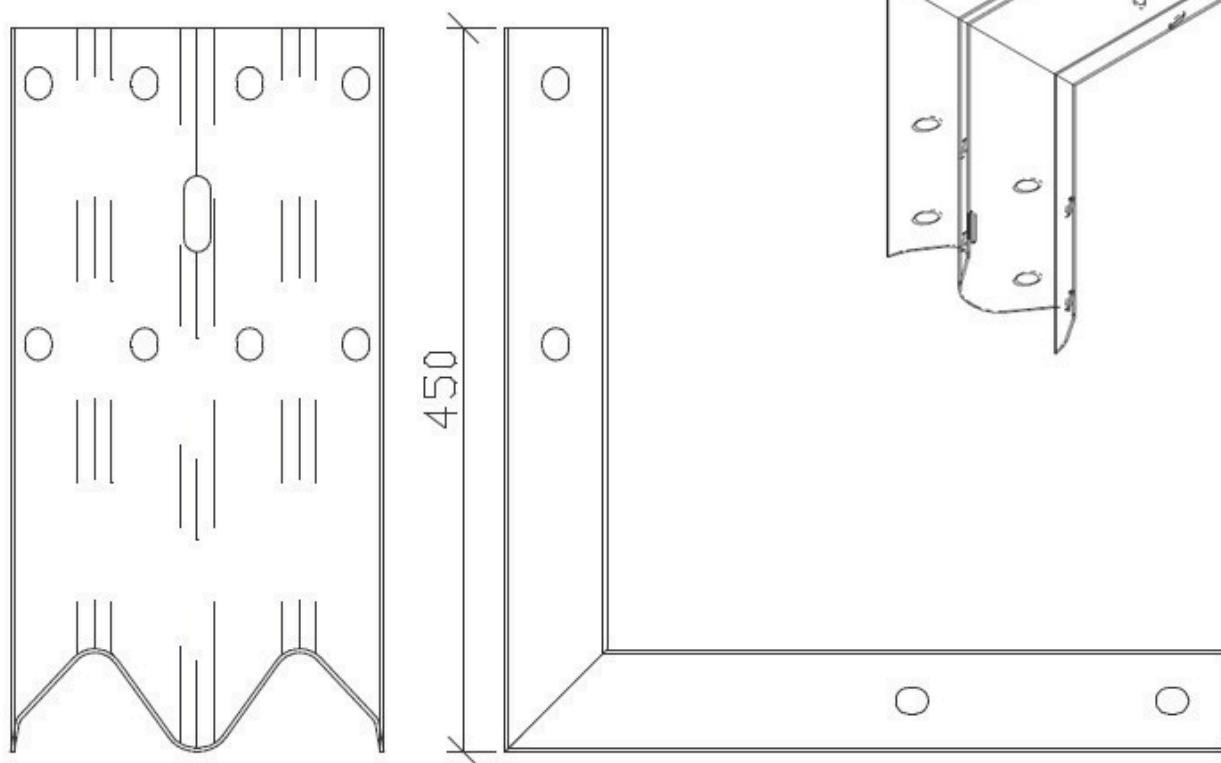

135° External Corner



SPECIFICATIONS	DETAILS
----------------	---------

Product Code	SKU: 755704
Material	Galvanised Steel
Height	315 mm
Width	450 mm
Length	450 mm
Fixing	8 x M16x35mm Lap Bolt

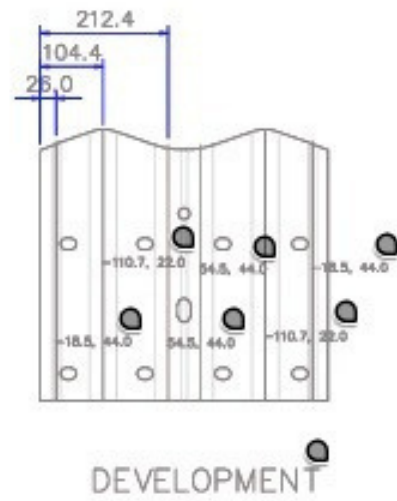
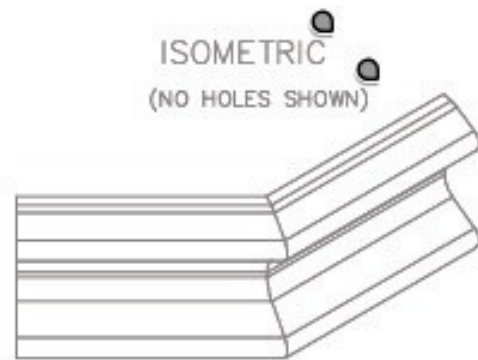
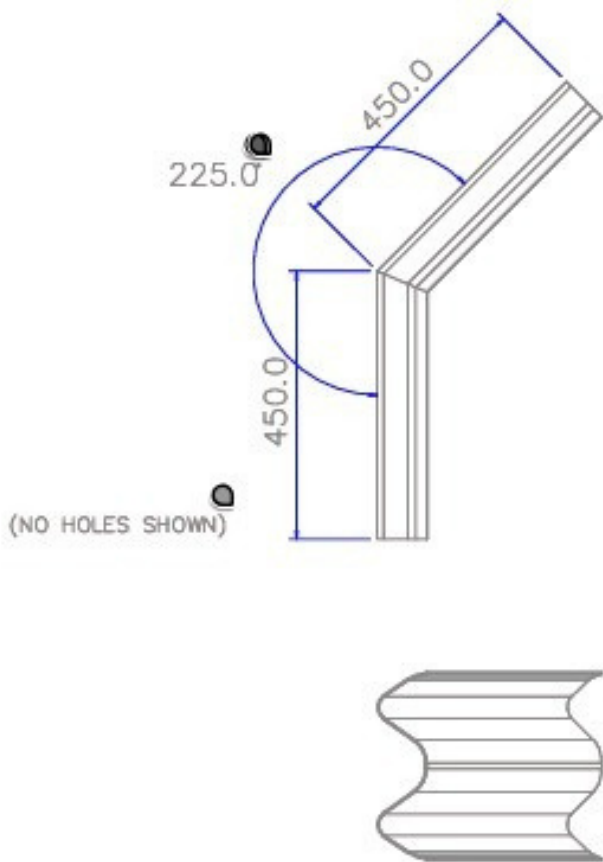

Yellow Polymer Pedestrian End with Reflectors



SPECIFICATIONS		DETAILS
Product	Code	SKU: 797889
Material		Polyethylene
Height		375 mm
Width		108 mm
Depth		165 mm

Yellow Polymer Safe End with reflectors



SPECIFICATIONS		DETAILS
Product	Code	SKU: 797878
Material		Polyethylene
Height		332 mm
Width		94 mm
Depth		105 mm

Plastic RSJ Post Cap



SPECIFICATIONS		DETAILS
Product Code		SKU: 755700
Material		PVC
Height		35 mm
Width		127 mm
Length		76 mm

PVC Beam End Sleeve



SPECIFICATIONS		DETAILS
Product Code		SKU: 755700
Material		Polyethylene
Height		400 mm
Length		280 mm
Width		2 mm
Use		Slots on to the beam to cover sharp edges Fixings: None Required



Installation

Barrier systems shall be installed on a suitable, level concrete foundation or approved substrate capable of supporting system loads.

Installation procedure:

Set out:

Mark the barrier line using string or chalk lines. Posts shall be positioned at 1600mm centres.

Drill and fix posts:

Use base plates as templates to mark fixing positions. Drill holes (Ø16mm typical) and fix posts using M16 x 125 mm galvanised anchor bolts. Do not fully tighten at this stage.

Install beams:

Fix beams to posts using M16 x 50mm galvanised post bolts. Connect beam overlaps using M16 x 35mm galvanised lap bolts. Leave all fixings loose.

Fit accessories:

Install corner sections and end terminals as required. Corners shall be supported by posts on both sides.

Align and secure:

Check line and level, then fully tighten all fixings, including anchor bolts.

Cutting and finishing (if required):

Cut beams using suitable equipment and treat any exposed steel with a zinc-rich coating.

Installation shall be carried out by a minimum of two operatives in accordance with relevant health and safety requirements. The performance of the system is dependent on the adequacy of the supporting ground or structure. This system is designed for use in controlled environments and is not suitable for roadside or highway applications.

Maintenance:

The barrier system shall be subject to periodic visual inspection to ensure continued performance and safety.

Checks should include fixings, alignment, and signs of damage or corrosion. Any loose fixings shall be tightened, and damaged components repaired or replaced as required. Exposed steel surfaces shall be treated with a zinc-rich coating to maintain protection.

